



## USER MANUAL

*PhG-ESS series low voltage module  
energy storage system*

Version : V1.3

PHASEGREEN TECHNOLOGY INC.

**Copyright © PHASEGREEN TECHNOLOGY INC. All rights reserved.**

No part of this document may be reproduced or transmitted in any form or by any means without prior written consent of PHASEGREEN TECHNOLOGY INC.

## **Trademarks and Permissions**

PhaseGreen and other PhaseGreen trademarks are trademarks of PHASEGREEN TECHNOLOGY INC.

All other trademarks and trade names mentioned in this document are the property of their respective holders.

### **Notice**

The purchased products, services and features are stipulated by the contract made between PhaseGreen and the customer. All or part of the products, services and features described in this document may not be within the purchase scope or the usage scope. Unless otherwise specified in the contract, all statements, information, and recommendations in this document are provided "AS IS" without warranties, guarantees or representations of any kind, either express or implied.

The information in this document is subject to change without notice. Every effort has been made in the preparation of this document to ensure accuracy of the contents, but all statements, information, and recommendations in this document do not constitute a warranty of any kind, express or implied.

### **PHASEGREEN TECHNOLOGY INC.**

Address: 3041 El Camino Real, Palo Alto, CA 94306, USA

EIN#: 88-3185469

Website: <http://www.phasegreen.com>

## Version History

Changes between document issues are cumulative. The latest document issue contains all the changes made in earlier issues.

Version 1.0 (2022-06-20)

Version 1.1 (2022-10-27) Update address

Version 1.2 (2023-03-11) Update company logo and system specifications

Version 1.3(2023-04-14) Update system specifications

PhaseGreen

## Content

Trademarks and Permissions .....	2
Content.....	4
1 Safety Precautions .....	6
1.1 General Safety .....	6
1.2 Personnel Requirements.....	8
1.3 Electrical Safety .....	8
1.4 Battery Safety .....	9
1.5 Transportation Requirements .....	13
1.6 Commissioning .....	14
1.7 Maintenance and Replacement .....	14
2 Product description.....	15
2.1 Product introduction.....	15
3 Installation guide .....	18
3.1 Environmental requirements.....	18
3.2 Installation physical requirements .....	19
3.3 Installation.....	24
3.3.1 Installation tools .....	24
3.3.2 Packaging components.....	24
3.4 Installation steps.....	26
4 Electrical connections .....	33
4.1 Grounding instructions.....	33
4.2 Power connector installation.....	34
4.3 Cable connection .....	35
4.3.1 Single cabinet cable connection.....	35
4.3.2 Cable connection of parallel cabinets.....	36
5 System commission .....	37
5.1 System power up steps .....	37
5.2 System power off steps .....	38
5.3 Display description .....	38
5.4 System configuration .....	39
Inverter manufacturer list: .....	41
6 Maintenance manual/general troubleshooting .....	42
6.1 Routine maintenance .....	42
6.2 Fault treatment.....	42
7 Warehouse storage guidelines .....	44

8	Dispose of used batteries .....	44
9	Detailed specification .....	44
10	Contact information.....	46

PhaseGreen

# 1 Safety Precautions

Read the manual carefully and operate in accordance with the safety precautions. Refer to local safety regulations on items not covered in this manual. Electrical installation, maintenance must be performed by professional / qualified personnel.

## 1.1 General Safety

### Declaration

Before installing, operating, and maintaining the equipment, read this document and observe all the safety instructions on the equipment and in this document.

The "NOTICE", "WARNING", and "DANGER" statements in this document do not cover all the safety instructions. They are only supplements to the safety instructions.

PhaseGreen will not be liable for any consequence caused by the violation of general safety requirements or design, production, and usage safety standards.

Ensure that the equipment is used in environments that meet its design specifications. Otherwise, the equipment may become faulty, and the resulting malfunction, component damage, personal injuries, or property damage are not covered under the warranty.

Follow local laws and regulations when installing, operating, or maintaining the equipment. The safety instructions in this document are only supplements to local laws and regulations.

PhaseGreen will not be liable for any consequences of the following circumstances:

- Operation beyond the conditions specified in this document
- Installation or use in environments that cannot meet relevant international, national, or local standards
- Unauthorized modifications to the product or software code or removal of the product
- Failure to follow the operation instructions and safety precautions on the product and in this document
- Equipment damage due to force majeure, such as earthquakes, fire, storms, floods, and debris flows
- Damage caused during transportation by the customer
- Damage caused by storage conditions that do not meet the requirements specified in related documents
- Damage to the hardware or data of the equipment due to customer's negligence, improper operation, or intentional damage
- System damage caused by improper operations of a third party or customer, including those in transportation, installation, and adjustment, alteration, or removal of identification marks

### General Requirements

---

#### **DANGER**

Improper operations on high-voltage equipment may cause an electric shock or fire, which could result in death, serious injury, or serious property damage. Perform standard operations as follows:

- Do not install, use, or operate outdoor equipment and cables (including but not limited to moving equipment, operating equipment and cables, inserting connectors to or removing connectors from signal ports connected to outdoor facilities, working at heights, and performing outdoor installation) in harsh weather conditions such as lightning, rain, snow, and level 6 or stronger wind.
- Observe the operation procedures and safety precautions provided in this manual and other related document.
- Observe the safety precautions specified in the warning signs and protection labels on the equipment.
- Use correct tools properly as required in this manual.
- Do not perform installation, cable connection, maintenance, or replacement when the equipment is power on.
- Do not clean the equipment with water.
- Do not open the host panel of the equipment.
- Check that the equipment is not damaged. For example, check that the battery is not dropped, bumped, or dented on the enclosure.
- Before handling a conductor surface or terminal, measure the contact point voltage and ensure that there is no risk of electric shock.
- Repaint any paint scratches caused during equipment transportation or installation in a timely manner. Equipment with scratches cannot be exposed to an outdoor environment for a long period of time.
- Ensure that battery terminal components are not affected during transportation. Do not hoist or move batteries by using battery terminals.
- Without prior consent from the manufacturer, do not alter the internal structure or installation procedure of the equipment.
- In the case of a fire, immediately leave the building or the equipment area, and turn on the fire alarm bell or make an emergency call. Do not enter the building on fire in any case.

---

**NOTICE**

- During transportation, turnover, installation, cable connection, and maintenance, comply with the national and local laws, regulations, and relevant standards.
- The materials and tools prepared by the customer must comply with the national and local laws, regulations, and relevant standards.
- Obtain approval from the national and local electric utility company before connecting the equipment to the grid.
- Understand the components and functioning of a grid-tied PV power system and relevant local standards.
- The materials and tools prepared by the customer must comply with the national and local laws, regulations, and relevant standards.
- Obtain approval from the national and local electric utility company before connecting the equipment to the grid.
- Understand the components and functioning of a grid-tied PV power system and relevant local standards.

---

You shall not reverse engineer, decompile, disassemble, adapt, add code to the device, software or alter the device software in any other way, research the internal implementation of the device, obtain the device software source code, infringe on PhaseGreen's intellectual property, or disclose any device software performance test results.

## 1.2 Personnel Requirements

- Personnel who plan to install or maintain PhaseGreen equipment must receive thorough training, understand all necessary safety precautions, and be able to correctly perform all operations.
- Only qualified professionals or trained personnel are allowed to install, operate, and maintain the equipment.
- Only qualified professionals are allowed to remove safety facilities and inspect the equipment.
- Personnel who will operate the equipment, including operators, trained personnel, and professionals, should possess the local national required qualifications in special operations such as high-voltage operations, working at heights, and operations of special equipment.
- Only professionals or authorized personnel are allowed to replace the equipment or components (including software).

### NOTE

- Professionals: personnel who are trained or experienced in equipment operations and are clear of the sources and degree of various potential hazards in equipment installation, operation, and maintenance.
- Trained personnel: personnel who are technically trained, have required experience, are aware of possible hazards on themselves in certain operations, and are able to take protective measures to minimize the hazards on themselves and other people.
- Operators: operation personnel who may come in contact with the equipment, except trained personnel and professionals.

## 1.3 Electrical Safety

### Grounding Requirements

- For the equipment that needs to be grounded, install the protective earthing (PE) cable first when installing the equipment and remove the PE cable last when removing the equipment.
- Do not damage the ground conductor.
- Do not operate the equipment in the absence of a properly installed ground conductor.
- Ensure that the equipment is connected permanently to the protective ground. Before operating the equipment, check the electrical connection to ensure that it is securely grounded.

### General Requirements

---

#### **DANGER**

Before connecting cables, ensure that the equipment is intact. Otherwise, electric shocks or fire may occur.

---

- Ensure that all electrical connections comply with local electrical standards.
- Obtain approval from the local electric utility company before using the equipment in grid-tied mode.
- Ensure that the cables you prepared meet local regulations.
- Use dedicated insulated tools when performing high-voltage operations.

### DC Operation

---

#### **DANGER**



Do not connect or disconnect power cables with power-on. Transient contact between the core of the power cable and the conductor will generate electric arcs or sparks, which may cause fire or personal injury.

- 
- Before connecting cables, switch off the disconnect on the upstream equipment to cut off the power supply if people may contact energized components.
  - Before connecting a power cable, check that the label on the power cable is correct.
  - If the equipment has multiple inputs, disconnect all the inputs before operating the equipment.

### Cabling Requirements

- When routing cables, ensure that a distance of at least 30 mm exists between the cables and heat-generating components or areas. This prevents damage to the insulation layer of the cables.
- Bind cables of the same type together. When routing cables of different types, ensure that they are at least 30 mm away from each other.
- Ensure that the cables used in a grid-tied PV power system are properly connected and insulated and meet specifications.
- The positions where cables are routed through pipes or holes must be protected to prevent the cables from being damaged by sharp edges or burrs.
- When the temperature is low, violent impact or vibration may damage the plastic cable sheathing. To ensure safety, comply with the following requirements:
  - Cables can be laid or installed only when the temperature is higher than 0°C. Handle cables with caution, especially at a low temperature.
  - Cables stored at subzero temperatures must be stored at room temperature for at least 24 hours before they are laid out.

## 1.4 Battery Safety

### Declaration

The Company shall not be liable for equipment functional abnormality, component damage, personal safety accident, property loss, or other damage caused by the following reasons:

- The batteries are not charged as required during storage, resulting in capacity loss or irreversible damage to the batteries.
- A battery is damaged, falls, or leaks due to improper operations or incorrect connection.
- After being installed and connected to the system, the batteries are not powered on in time, which causes damage to the batteries due to over discharge.
- Battery running parameters are incorrectly set.
- The customer or a third party uses the batteries beyond the scenarios specified by the Company. For example, connect extra loads, or use with other batteries, including but not limited to batteries of other brands or batteries of different rated capacities.
- Damage is caused to batteries because the battery operating environment or external power parameters do not meet environment requirements. The actual operating temperature of batteries is too high or too low, or the power grid is unstable and experiences outages frequently.
- Batteries are frequently over discharged due to improper maintenance, capacity is incorrectly expanded, or the batteries have not been fully charged for a long time.

- Batteries are not maintained based on the operation guide, such as failure to check battery terminals regularly.
- Batteries are stolen.
- The warranty period of batteries has expired.

### Basic Requirements

---

#### **DANGER**

- Do not expose batteries at high temperature environment or around heat-generating sources, such as sunlight, fire sources, transformers, and heaters. The battery may cause a fire if overheated.
  - To avoid leakage, overheating, or fire, do not disassemble, alter, or damage batteries. For example, do not insert foreign objects into batteries or place batteries in water or other liquids.
  - Battery electrolyte is combustible, toxic, and volatile.
  - Battery thermal runaway can generate flammable gas and harmful gas such as CO and HF.
- 

- The batteries must be stored separately inside the packaging. Do not store batteries together with other materials or in the open air. Do not stack batteries too high.
- Do not use batteries beyond the warranty period.
- Do not remove the battery packaging before use. Batteries should be charged during storage by professionals as required. Put batteries back to their packaging after charge during storage.
- Move batteries in the correct direction. Do not place a battery upside down or tilt it.
- Protect batteries from impact.
- Do not perform welding or grinding work around batteries to prevent fire caused by electric sparks or arcs.
- Use batteries within the temperature range specified in this manual.
- Do not use damaged batteries (such as damage caused when a battery is dropped, bumped, or dented on the enclosure). Damaged batteries may release flammable gases. Do not store damaged batteries near undamaged products.
- Do not place damaged batteries in close proximity to flammable materials. Do not approach the damaged batteries unless you are a professional.
- Monitor damaged batteries during storage for signs of smoke, electrolyte leakage, or heat.

### Personal Safety

- Wear proper personal protective equipment (PPE) during operation. If there is a probability of personal injury or equipment damage, immediately stop the operations, report the case to the supervisor, and take feasible protective measures.
- Use tools correctly to avoid hurting people or damaging the equipment.
- Do not touch the energized equipment, as the enclosure is hot.
- To ensure personal safety and normal use of the equipment, the equipment must be reliably grounded before use.
- When a battery is faulty, the temperature may exceed the burn threshold of the touchable surface. Therefore, avoid touching the battery.
- Do not disassemble or damage the battery. The released electrolyte is harmful to your skin and eyes. Avoid contact with the electrolyte.

- Do not place irrelevant objects on the top of the equipment or insert them into any position of the equipment.
- Do not place inflammables around the equipment.
- To prevent explosions and body injury, do not place batteries in a fire. Do not place the battery in water or other liquids.
- Do not short-circuit wiring terminals of batteries. Short circuits can cause a fire.
- Batteries may cause electric shocks and high short-circuit currents. When using the battery, pay attention to the following points:
  - (a) Remove any metal objects from yourself, such as watches and rings.
  - (b) Use tools with insulated handles.
  - (c) Wear rubber gloves and boots.
  - (d) Do not place tools or metal parts on top of batteries.
  - (e) Before connecting or disconnecting battery terminals, disconnect the charging power supply.
  - (f) Check whether batteries are accidentally grounded. If it is accidentally grounded, remove the power supply from the ground. Touching any part of a grounded battery can cause an electric shock. If these grounding points are removed during installation and maintenance, the possibility of electric shocks can be reduced.
- Do not use water to clean electrical components inside or outside of a cabinet.
- Do not stand on, lean on, or sit on the top of the equipment.
- Do not damage the modules of the equipment.

### Battery Emergency Measures

---

#### **DANGER**

- Avoid contact with leaked liquids or gases in the case of battery leakage or abnormal odor. Do not approach the battery. Contact professionals immediately. Professionals must wear safety goggles, rubber gloves, gas masks, and protective clothing.
  - Electrolyte is corrosive and can cause irritation and chemical burns. Should you come into direct contact with the battery electrolyte, do as follows:
  - Inhalation: Evacuate contaminated areas, get fresh air immediately, and seek immediate medical attention.
  - Eye contact: Immediately flush your eyes with water for at least 15 minutes, do not rub your eyes, and seek medical attention immediately.
  - Skin contact: Wash the affected areas immediately with soap and water and seek medical attention immediately.
  - Ingestion: Seek immediate medical attention.
- 

### Fire Emergency Measures

---

#### **DANGER**

- If a fire occurs, power off the system if it is safe to do so.
- Extinguish the fire with carbon dioxide, FM-200 or ABC dry powder fire extinguishers.
- Ask firefighters to avoid contact with high-voltage components during firefighting to prevent the risk of electric shock.

- Overheating may cause batteries to deform and leak corrosive electrolyte or toxic gas. Keep away from the batteries to avoid skin irritation and chemical burns.
- 

### Flood Emergency Measures

---

**DANGER**

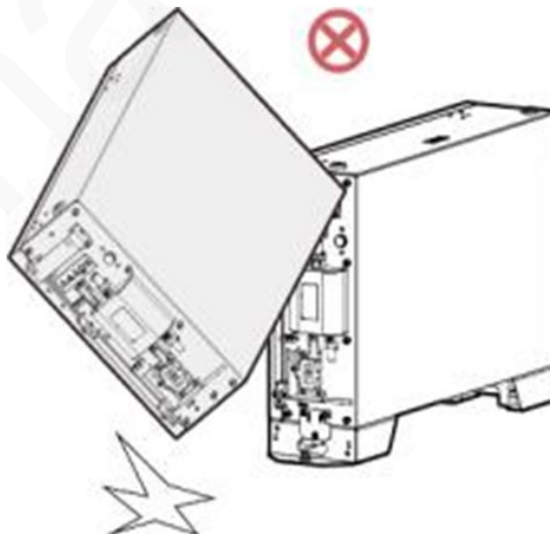
- Power off the system if it is safe to do so.
  - If any part of the batteries is submerged in water, do not touch the batteries to avoid electric shock.
  - Do not use batteries that have been soaked in water. Contact a battery recycling company for disposal.
- 

### Dropped Battery Emergency Measures

---

**DANGER**

- If a battery pack is dropped or violently impacted during installation, internal damage may occur. Do not use such battery packs; otherwise, safety risks such as cell leakage and electric shock may arise.
  - If a dropped battery has obvious damage or abnormal odor, smoke, or fire occurs, evacuate the personnel immediately, call emergency services, and contact the professionals. The professionals can use fire extinguishing facilities to extinguish the fire under safety protection.
  - If a dropped battery has no obvious deformation or damage and no abnormal odor, smoke, or fire occurs, contact the professionals to transfer the battery to an open and safe place, or contact a recycling company for disposal.
- 



### Battery Recycling

- Dispose of used batteries in accordance with local laws and regulations. Do not dispose of batteries as household waste.
- If the batteries leak or are damaged, contact technical support or a battery recycling company for disposal.
- If the batteries are out of service life, contact a battery recycling company for disposal.
- Do not expose batteries to high temperatures or direct sunlight.
- Do not expose batteries to high humidity or corrosive environments.

## 1.5 Transportation Requirements

---

### NOTICE

The product passes the certifications of the UN38.3 (UN38.3: Section 38.3 of the sixth Revised Edition of the Recommendations on the Transport of Dangerous Goods: Manual of Tests and Criteria) and SN/T 0370.2-2009 (Part 2: Performance Test of the Rules for the Inspection of Packaging for Exporting Dangerous Goods). This product belongs to Class 9 dangerous goods.

---

#### Loading and unloading:

Load and unload the batteries in compliance with local laws, regulations, and industry standards. Reckless handling may cause short circuits or damage to batteries in the container, which may result in battery leakage, rupture, explosion, or fire.

#### Before transportation:

- Check that the batteries are intact and there is no obvious odor, smoke, or fire. Otherwise, the batteries cannot be transported.

### NOTE

The product can be delivered to the site directly and transported by land and water. The packing case must be secured for transportation. Handle the product with care during loading, unloading, and transportation with moisture-proof measures in place. The actual capacity may vary depending on the environment conditions, such as temperature, transportation conditions, and storage conditions.

#### During transportation:

- The batteries cannot be transported by rail or air.
- Maritime transport must comply with the International Maritime Dangerous Goods Code (IMDG Code).
- Road transport must comply with the International Carriage of Dangerous Goods by Road (ADR) or JT T617.
- Comply with the requirements of the transportation regulatory authorities in the countries of departure, route, and destination.
- Comply with the international regulations on the transport of dangerous goods and the requirements of the transport regulatory authorities of the respective countries.

Protect the packing case with the product from the following situations:

- Being dampened by rains, snows, or falling into water.
- Falling or mechanical impact.
- Being upside-down or tilted.

**NOTE**

If any of the preceding exceptions occurs, take the emergency measures.

## 1.6 Commissioning

When the equipment is powered on for the first time, ensure that professional personnel set parameters correctly. Incorrect settings may result in inconsistency with local certification and affect the normal operation of the equipment.

## 1.7 Maintenance and Replacement

---

**DANGER**

High voltage generated by the equipment during operation may cause an electric shock, which could result in death, serious injury, or serious property damage. Prior to maintenance, power off the equipment and strictly comply with the safety precautions in this document and relevant documents.

---

- Maintain the equipment with sufficient knowledge of this document and using proper tools and testing equipment.
- Before maintaining the equipment, power it off and follow the instructions on the delayed discharge label to ensure that the equipment is powered off.
- Place temporary warning signs or erect fences to prevent unauthorized access to the maintenance site.
- If the equipment is faulty, contact your dealer.
- The equipment can be powered on only after all faults are rectified. Failing to do so may escalate faults or damage the equipment.
- Do not open the cover without authorization. Otherwise, electric shocks may occur, and the resulting faults are beyond warranty scope.
- Installation personnel, maintenance personnel, and technical support personnel must be trained to operate and maintain the equipment safely and correctly, take comprehensive precautionary measures, and be equipped with protective instruments.
- Before moving or reconnecting the equipment, disconnect the mains and batteries and wait for five minutes until the equipment powers off. Before maintaining the equipment, check that no dangerous voltages remain in the DC bus or components to be maintained by using a multimeter.
- Battery maintenance should be carried out or supervised by personnel who are familiar with batteries and the precautions required.
- When replacing batteries, replace them with batteries or battery strings of the same type.
- Take out all tools and parts from the equipment after maintenance is complete.
- If the equipment is not used for a long time, store and recharge batteries according to this document.

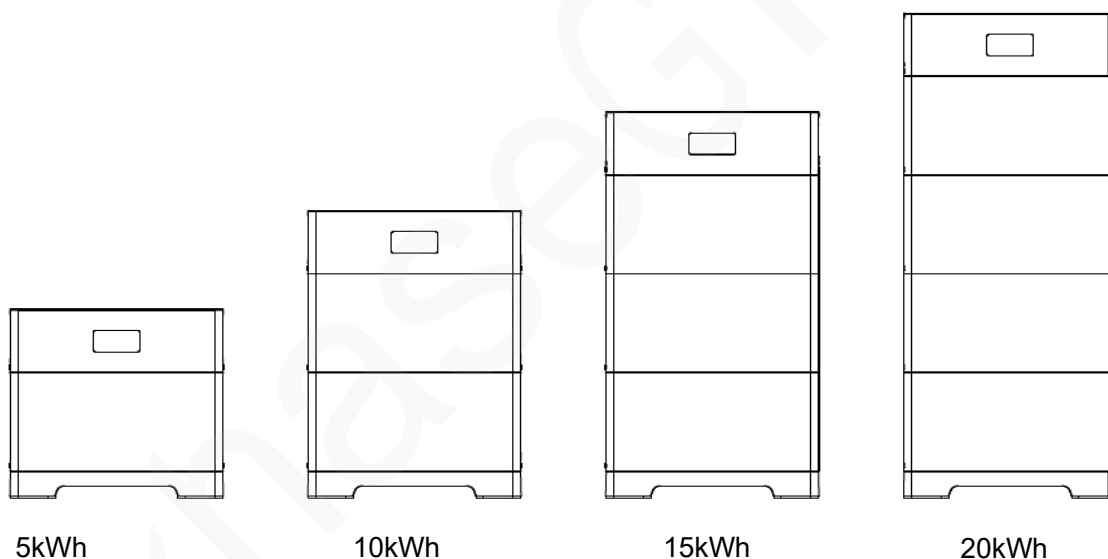
## 2 Product description

PhG-ESS-(xx)L is a plug-in energy storage system compatible with for majority PCS brands. This document provides product introduction, installation, commissioning, maintenance, troubleshooting, packaging and transportation information.

### 2.1 Product introduction

- Residential energy storage system with lithium iron phosphate (LFP) technology.
- Modular design; single battery system has 5 to 20kWh (1 – 4 pcs batteries) , must be used with the control module and base.
- Indoor or outdoor installation (IP55).
- Expandable to 60kWh (3 systems connected in parallel).
- PCS communication interface: CAN or RS485.
- No degradation in performance at -10°C.

Advanced battery management system (BMS) provides data acquisition, status monitoring and control to ensure the safe and reliable operation of the system.



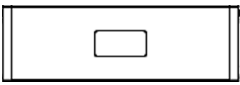

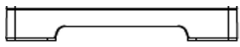
	Control module (1 PCS)
	Battery (1 to 4 PCS)
	Mounting base (1 PCS)

Figure 2-1-1 PhG-ESS-(x)L configuration

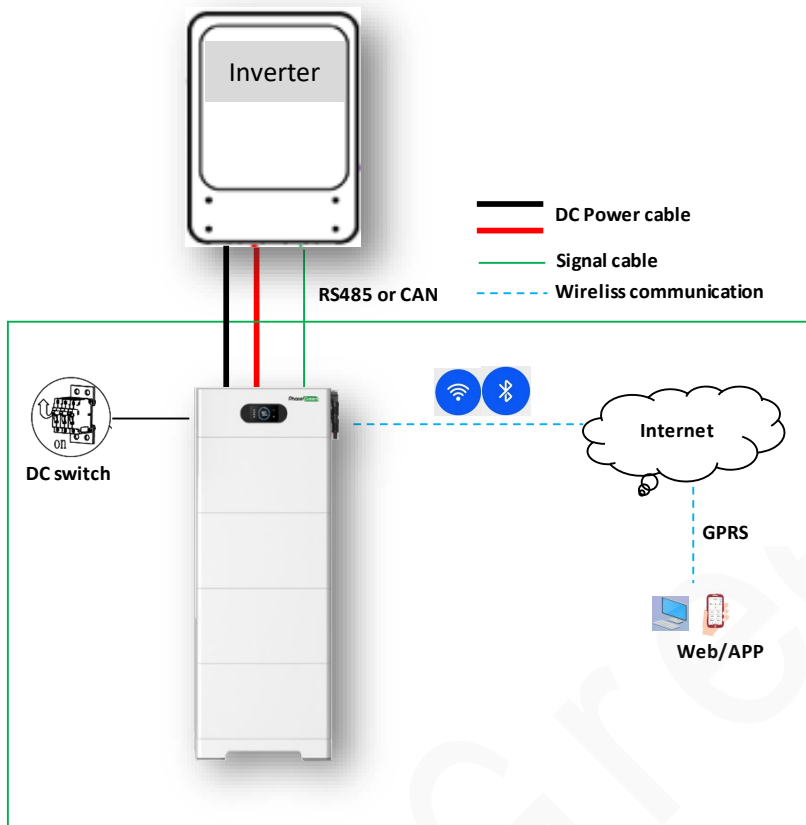


Figure 2-1-2 System topology

- Appearance of the whole system

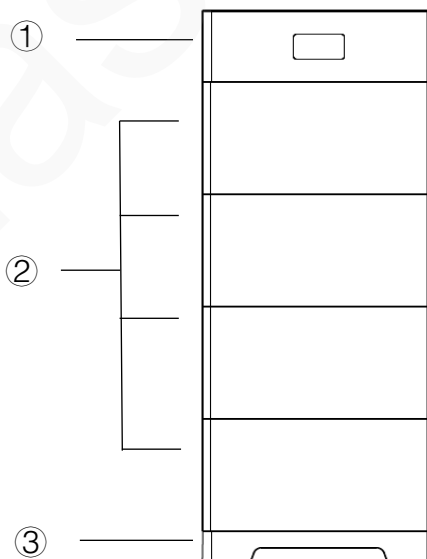


Figure 2-2-1 Appearance of the whole system

① Control module	② Battery module	③ Mounting base
------------------	------------------	-----------------



- Control module

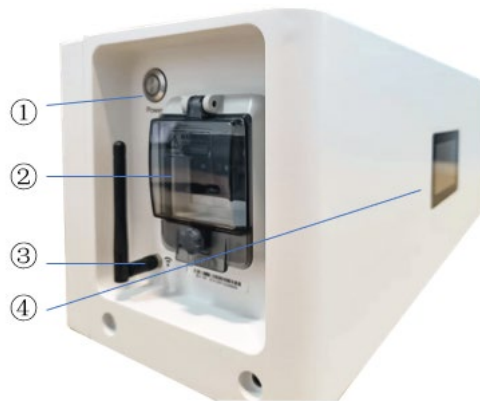


Figure 2-2-2 Left side of Control module

① Power button	② DC breaker	③ Wi-Fi antenna	④ Display screen
----------------	--------------	-----------------	------------------



Figure 2-2-3 Right side of the control module

① Output Negative (DC-)	② Output Positive (DC+)
③ Parallel communication 0 (COM0)	④ Parallel communication 1 (COM1)
⑤ PCS communication (485/CAN)	⑥ Maintenance (LAN)
⑦ Protection earth (PE)	

- Battery module

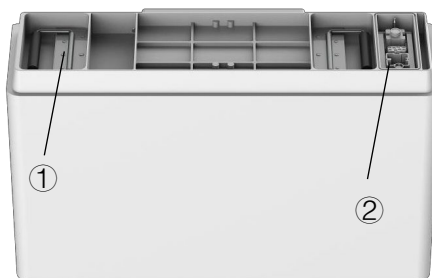


Figure 2-2-4 Structure diagram of battery

① Handle	② Power/communication connector
----------	---------------------------------

- Mounting base

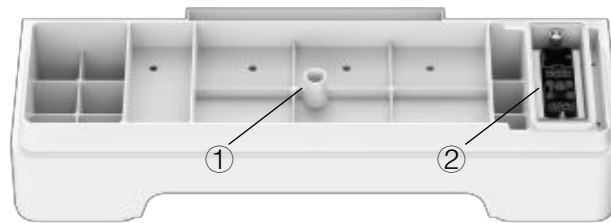


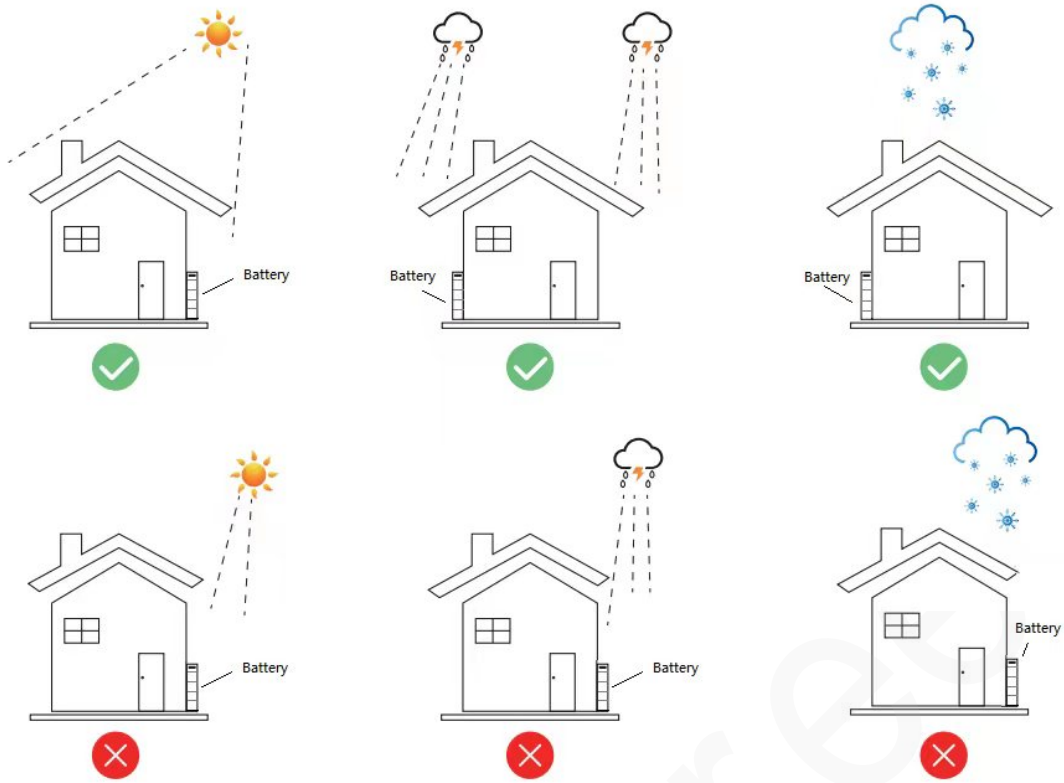
Figure 2-2-5 Structure diagram of Base

① Positioning	② Connector positioning
---------------	-------------------------

## 3 Installation guide

### 3.1 Environmental requirements

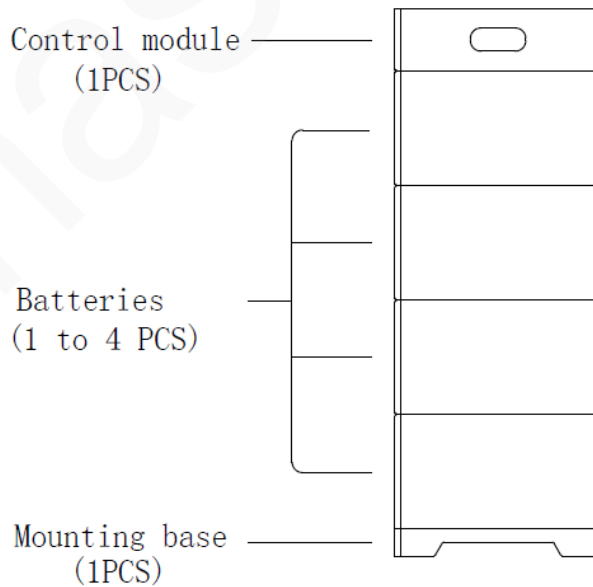
- Operating temperature:  $-10^{\circ}\text{C}$  to  $50^{\circ}\text{C}$  or  $14^{\circ}\text{F}$  to  $122^{\circ}\text{F}$  (Optimal temperature:  $10^{\circ}\text{C}$  to  $35^{\circ}\text{C}$  or  $50^{\circ}\text{F}$  to  $95^{\circ}\text{F}$ )
- Ambient humidity: 10-95%.
- Altitude  $\leq 2000\text{m}$  or 6562 ft.
- For outdoor installation
  - Avoid direct sunlight
  - Avoid rain and snow
  - Avoid location susceptible to flooding
  - Install under shed if possible
- For indoor installation
  - 3 feet clearance from doors, windows, driveway or other batteries
  - Keep away from heating device.
  - Prevent from corrosive chemicals
  - Prevent from water spillage
  - Consider location equipped with ventilation fans, smoke, heat, or flammable gas detector



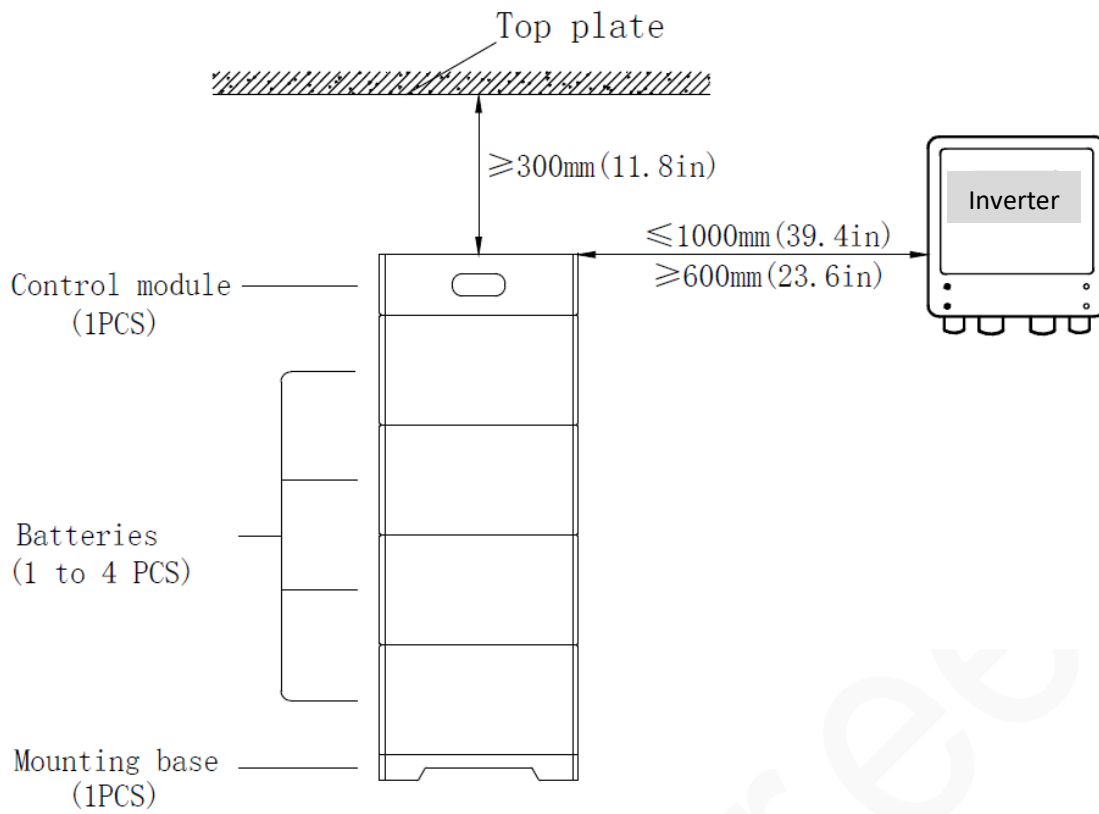
 PhG-ESS performance degrades when ambient temperature is below 10°C (50 °F) or above 40°C (104 °F) degrees.

### 3.2 Installation physical requirements

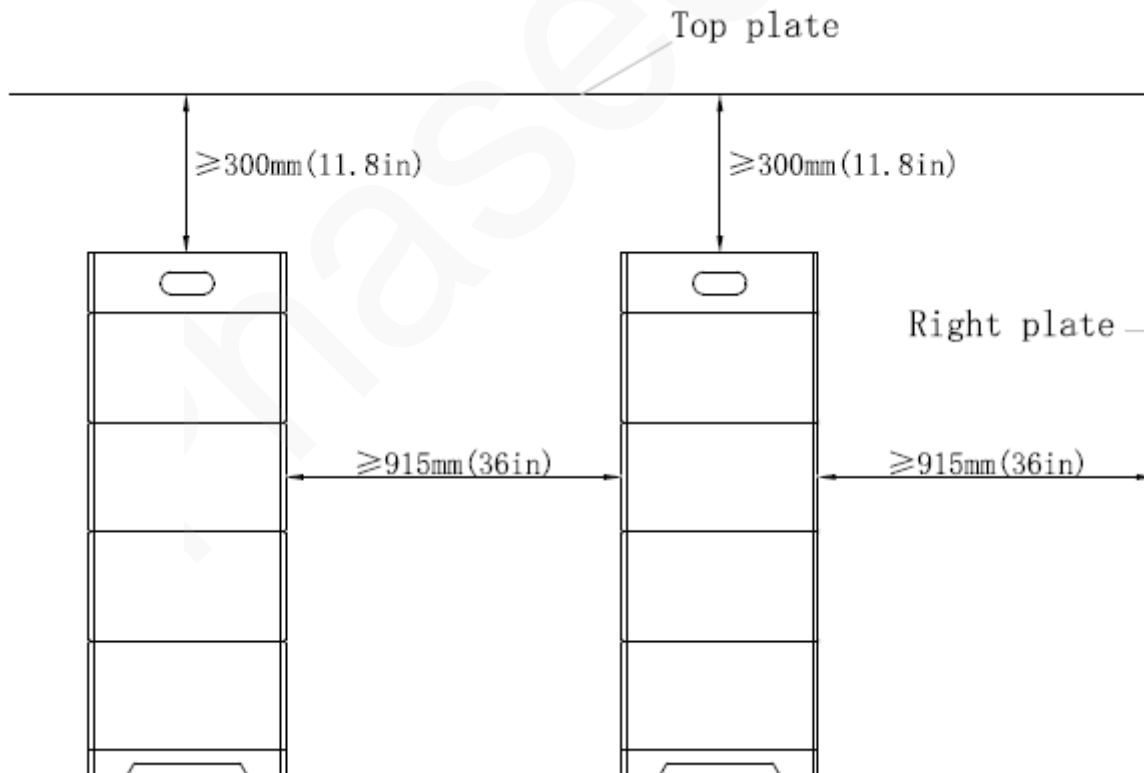
#### a. Correct battery quantity for installation



#### b. Recommend installation clearance

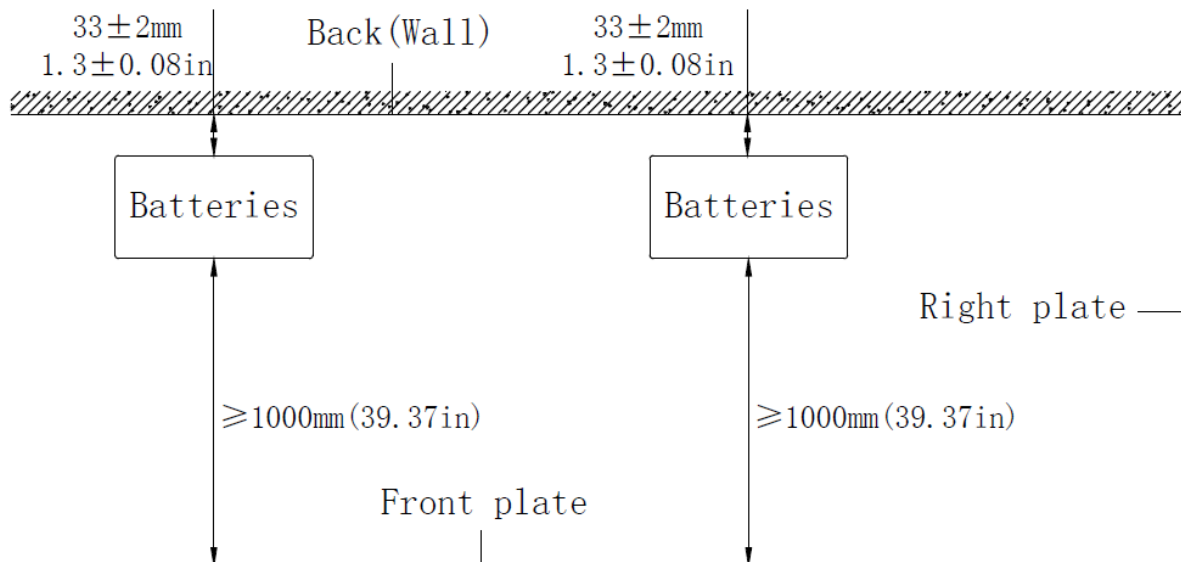


Main view:



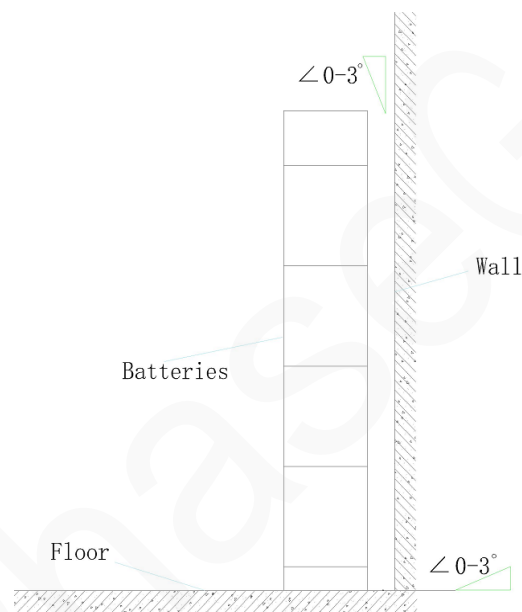
Top view:

**NOTE:** The back distance against the wall must be according to this size.



### c. Level control

Please keep the angle of the product to the ground between  $0$  and  $3^\circ$ , the angle of the product to the wall between  $0$  and  $3^\circ$ .



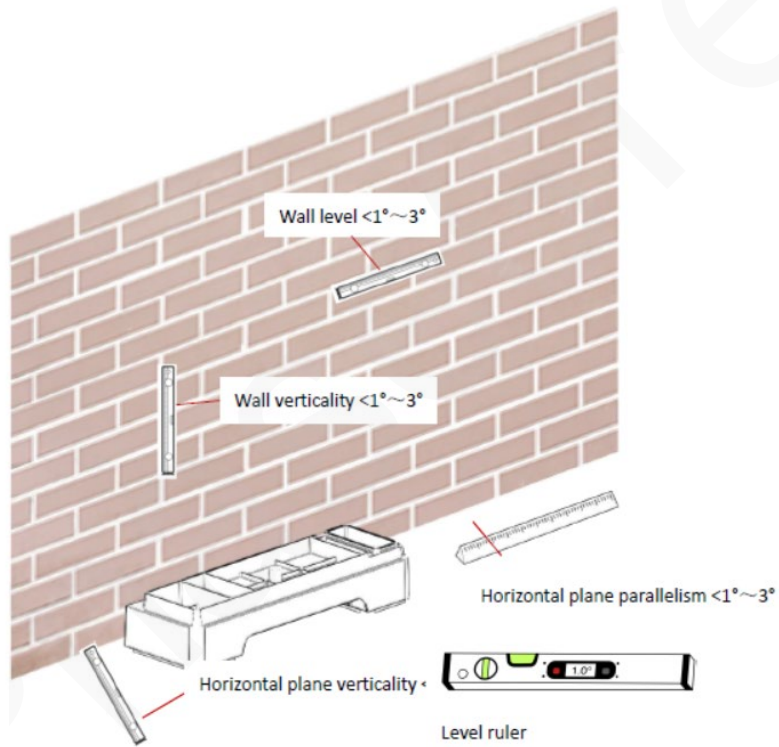
### d. Prepare the wall-mounting surface before drilling



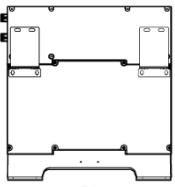
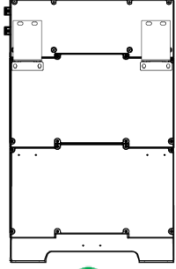
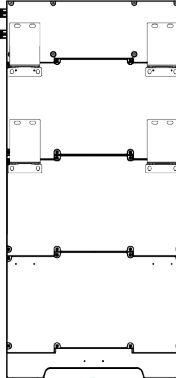
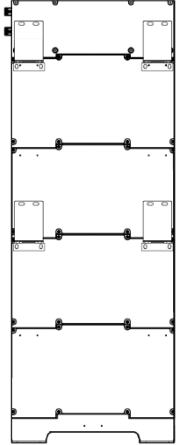
Before drilling, it is necessary to detect whether there is no metal wire inside the wall, avoid the electric circuit in the wall, and make a mark. For wooden wall, install the fixing screw on the wooden stake.



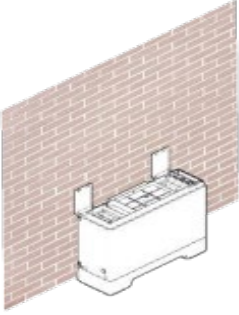

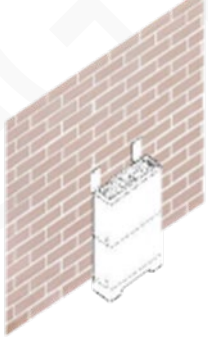

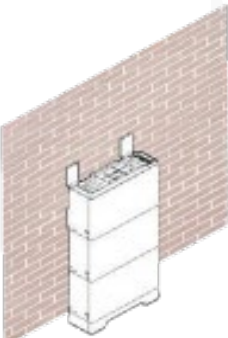

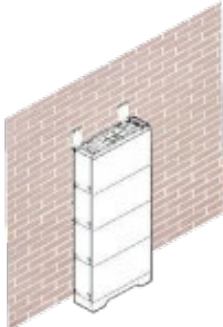

e. Use a spirit level to measure the level of the floor and the verticality of the wall



f. Refer to the following for the recommended the wall mounting assembly (angle bracket and L-bracket)

 <p style="text-align: center;">✓</p>	 <p style="text-align: center;">✓</p>	 <p style="text-align: center;">✓</p>	 <p style="text-align: center;">✓</p>
<p>1 mounting assembly on Batt. No.1</p>	<p>1 mounting assembly on Batt. No.2</p>	<p>2 pcs mounting assembly on Batt. No.2 and Batt. No.3</p>	<p>2 pcs mounting assembly on Batt. No.2 and Batt. No.4</p>

g. Refer to the following for the recommended position to install the L-brackets:

<b>PhG-ESS-5L</b>		<b>PhG-ESS-10L</b>	
Concrete wall	Wooden wall	Concrete wall	Wooden wall
			
<b>PhG-ESS-15L</b>		<b>PhG-ESS-20L</b>	
Concrete wall	Wooden wall	Concrete wall	Wooden wall
			

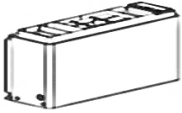
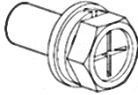

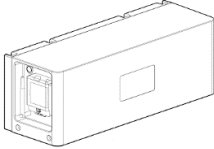
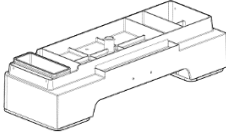
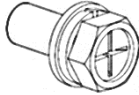





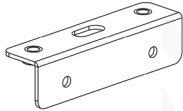

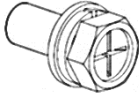

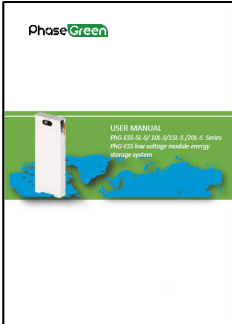
### 3.3 Installation




#### 3.3.1 Installation tools

Working Equipment			
			
Impact drill $\Phi$ 10mm or 3/8 drill	Torque wrench	Marker pen	Vacuum cleaner
			
Torque wrench	Torque screwdriver	Steel tape	Level ruler
			
Electric batch with M6 socket	Detector	Hammer	
Personal Protective Equipment			
			
Safety gloves	Safety goggles	Dust mask	Safety shoes

#### 3.3.2 Packaging components



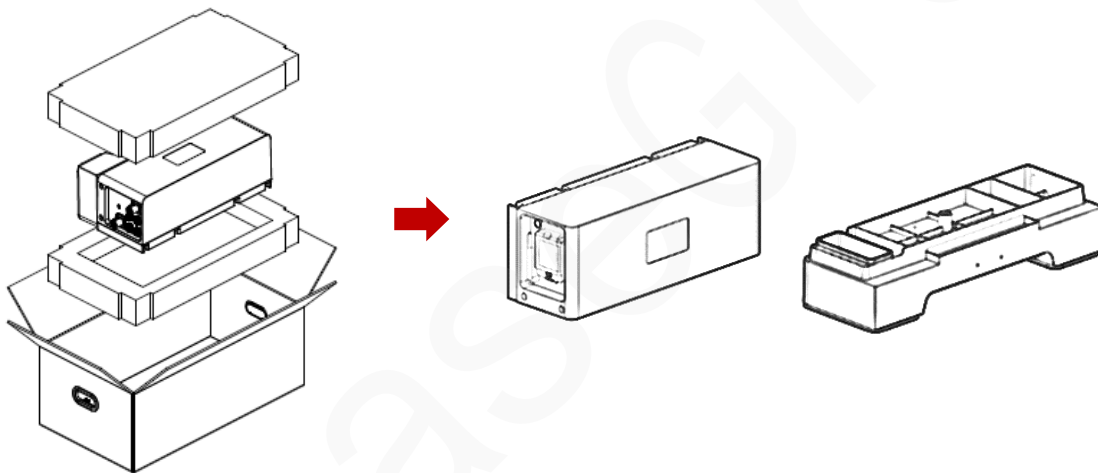
Battery Packaging Components			
			
Battery module (Qty:1pcs)	Fixing screws (M5*12) (Qty:4pcs)	screw cover (Qty:4pcs)	
Control Module Packaging Components			
			
Control module (Qty:1pcs)	Mounting base (Qty:1pcs)	Fixing screws (M5*12) (Qty:12pcs)	screw cover (Qty:4pcs)
			
Expansion screw M8*80 (Qty:4pcs)	M8 flange nuts (Qty:4pcs)	Self-tapping screws M6*60 (Qty:4pcs)	M6*18*2 large flat pad (Qty:4pcs)
			
Angle bracket (Qty:4pcs)	L-bracket X4 (Qty:4pcs)	Fixing screws (M6*14) (Qty:8pcs)	Grounding Terminals (Qty:1pcs)
			
User manual (Qty:1pcs)			

Cable kit Packaging Components		
		
Positive wire harness 1.5m (Qty:1pcs)	Negative wire harness 1.5m (Qty:1pcs)	PCS-RS485/CAN communication cable 2m (Qty:4pcs)

### 3.4 Installation steps

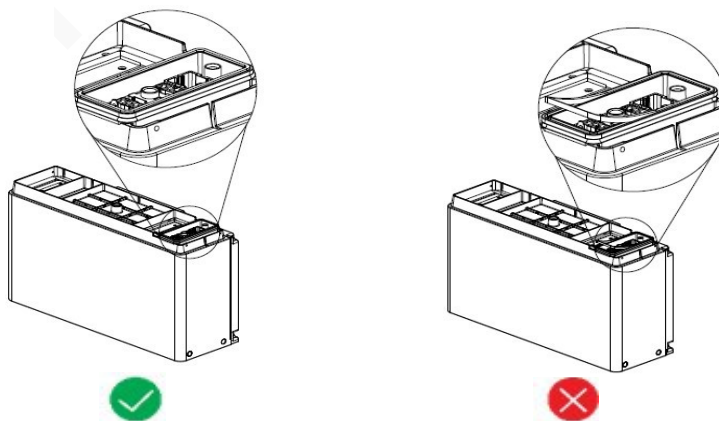
a. Place the mounting base

Take the control module and base out of the carton and separate them.

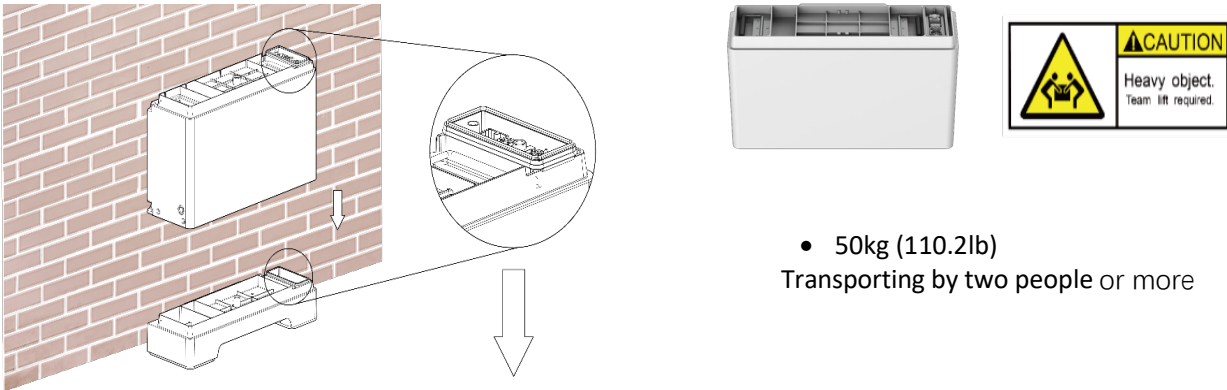


b. Install the battery module

Please check that the terminal sealing ring is well fixed before stack battery.

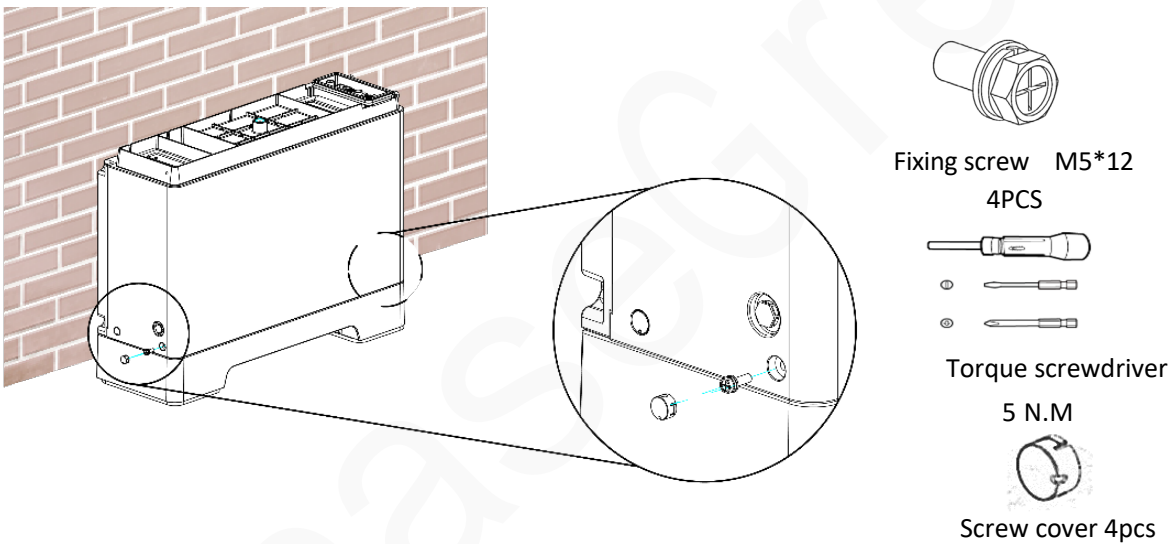


Align one end of the connector first, then slowly drop the battery in parallel to the mounting base.

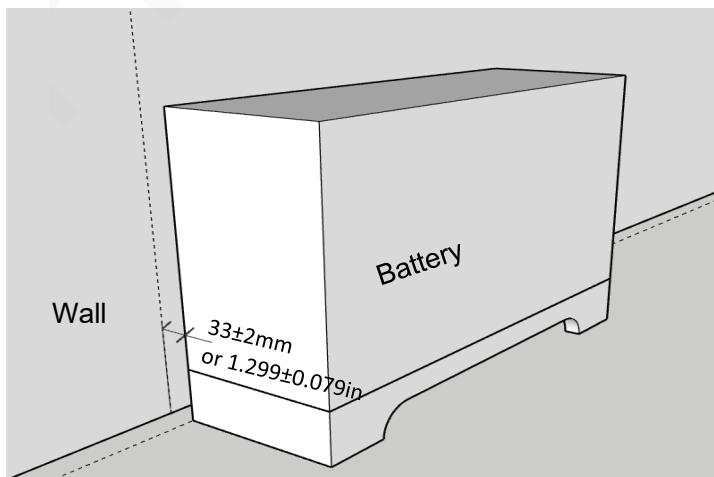


**Warning!** Do not drop the non-connector end first to avoid damage to the connector!

- Lock the screws on both sides of the battery and install the screw cover after the screws are fastened.

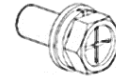
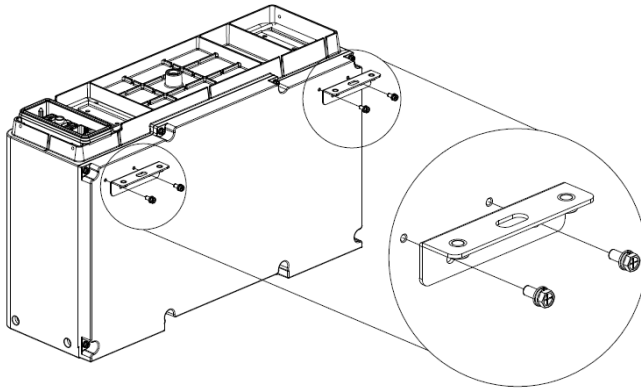


c. Adjust the distance between the battery and the wall to  $33\pm 2\text{mm}$  or  $1.299\pm 0.079\text{ inch}$



d. Adding additional battery module

- Install the angle bracket, (layout configuration reference 3.2 f.)

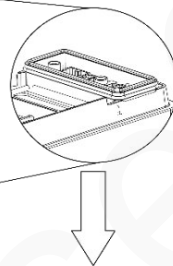
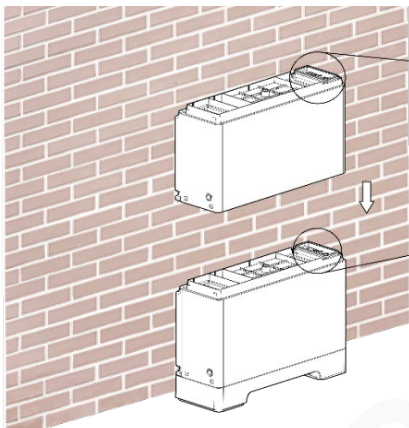


Fixing screw M5\*12  
4PCS



Torque screwdriver  
5 N.M

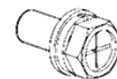
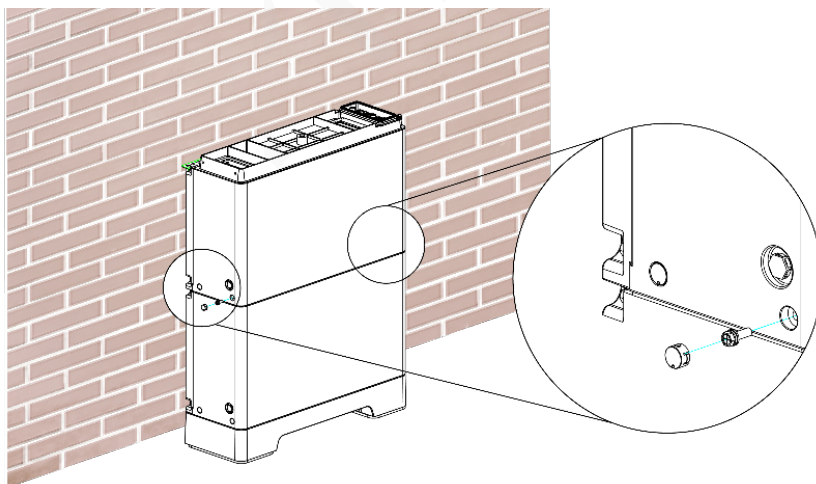
- Align one end of the connector first, then slowly drop the battery module in parallel.



- 50kg (110.2lb)  
Transporting by two people

**Warning!** Do not drop the non-connector end first to avoid damage to the connector!

- Lock the screws on both sides of the battery module and install the screw cover after the screws are fastened.



Fixing screws M5\*12  
4pcs



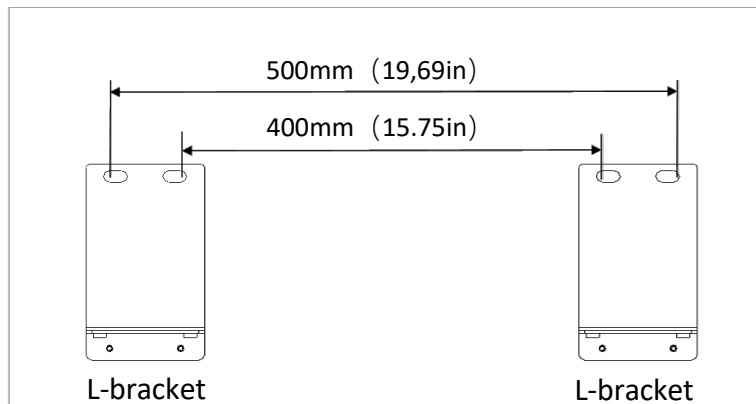
Torque screwdriver  
5 N.M



Screw cover 4pcs

e. Install L-bracket to wall:

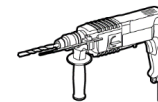
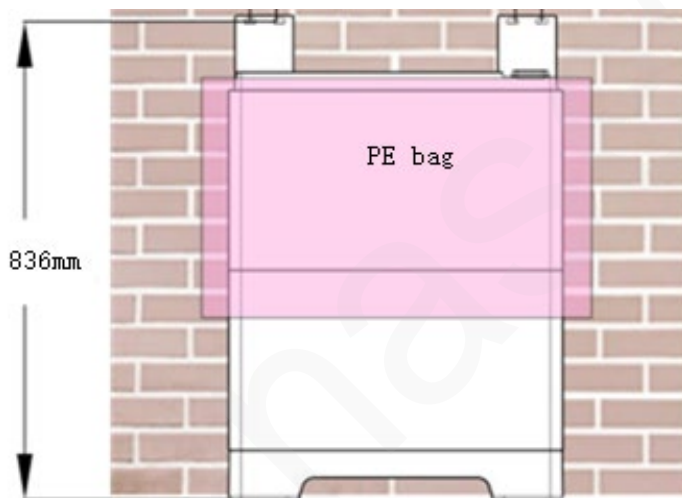
Mark the hole position (layout configuration reference 3.2 g.). Place the L-bracket against the wall on the corner bracket and mark the hole with a marker, the punching position is as shown in the figure.



### If Concrete wall

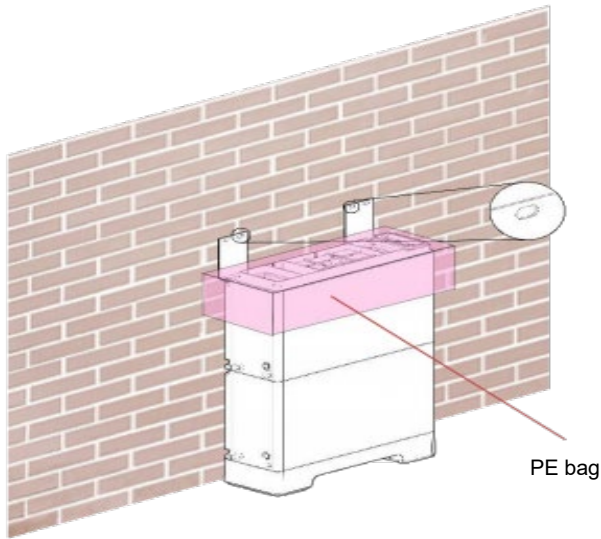
#### 1. Punching

The punching position is shown in the figure. When punching, remove the L-bracket and cover the PE bag of the product packaging with the battery to prevent dust from falling on the battery during punching.



#### 2. Install expansion screws

Knock in expansion screws at the holes.



Hamm



Expansion screw M8\*80

4pcs



M8 flange nuts

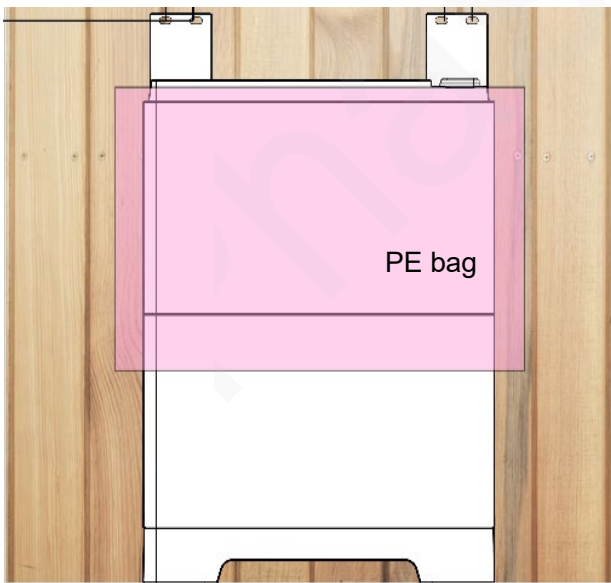
4pcs

**3. Install the L-bracket to Concrete wall**

Use a vacuum cleaner to absorb the dust, do not let the dust fall on the product, then remove the PE bag, place the wall bracket on the fixed bracket, lock the screw to fix it, and then insert the flange nut into the expansion screw.

**If Wooden wall:**

1. Put the PE bag of the product packaging on the battery to prevent the sawdust from falling on the battery when the installation is automatically settled, and use electric batch install the self-tapping screw M6-60 directly.
2. After that, use a vacuum cleaner to suck up the sawdust, do not let the sawdust fall on the product, and then remove the PE bag.



Electric batch with M6 socket



Self-tapping screws M6-60

4pcs



Vacuum cleaner



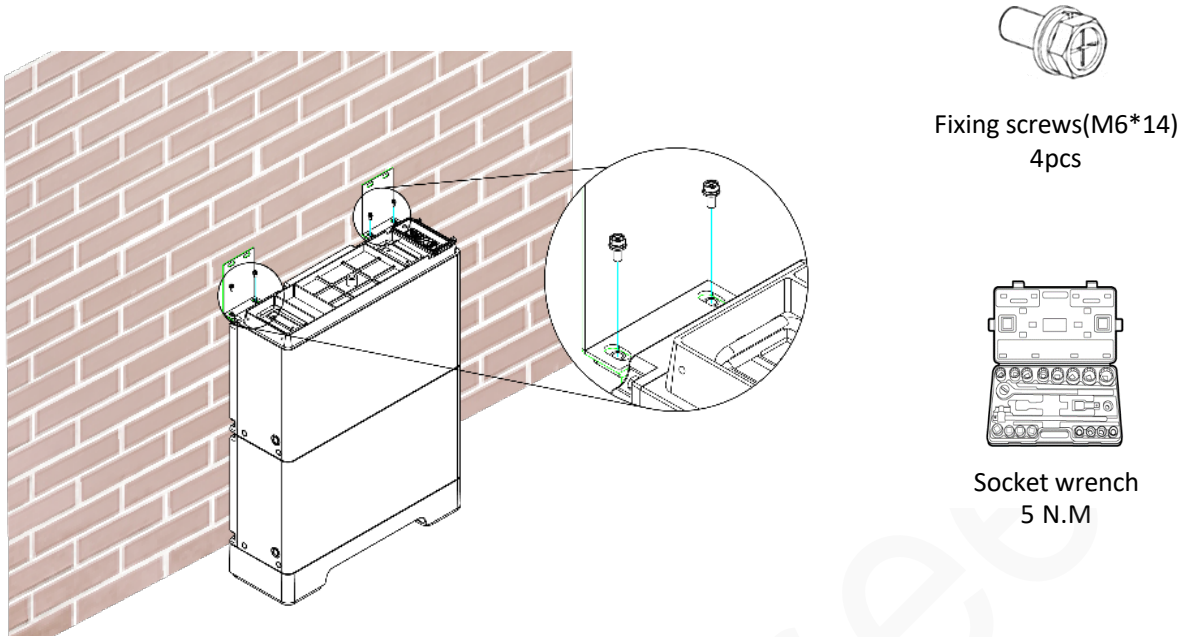
M6\*18\*2 large flat pad

4pcs



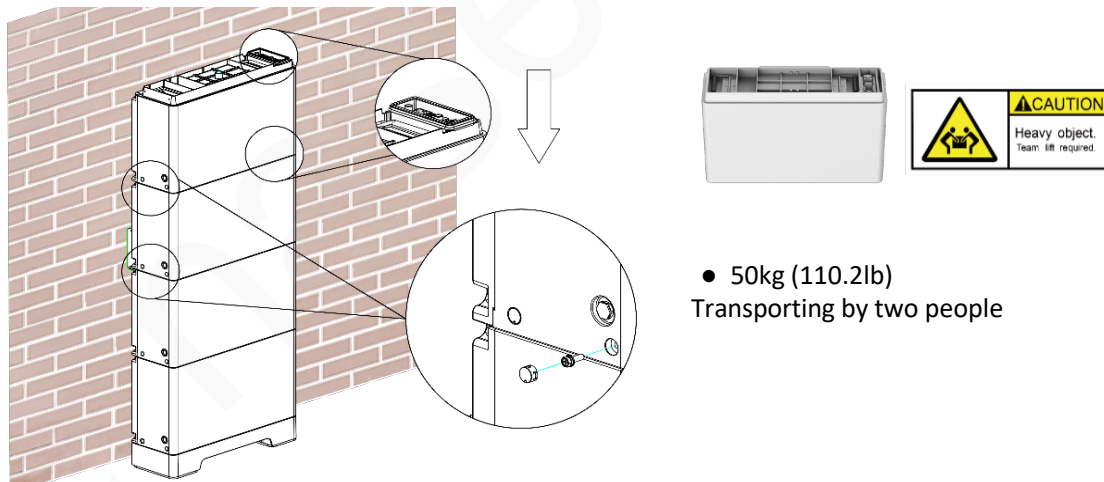
f. Install the L-bracket to the Angle bracket :

Put the L-bracket on the angle bracket and lock the screws to fix it



g. Stacking battery (up to 4 batteries)

When stacking the third and fourth battery, align one end of the connectors and then drop them synchronously. For each battery stacked, lock the screws on both sides to fix it and then install the screw cover.

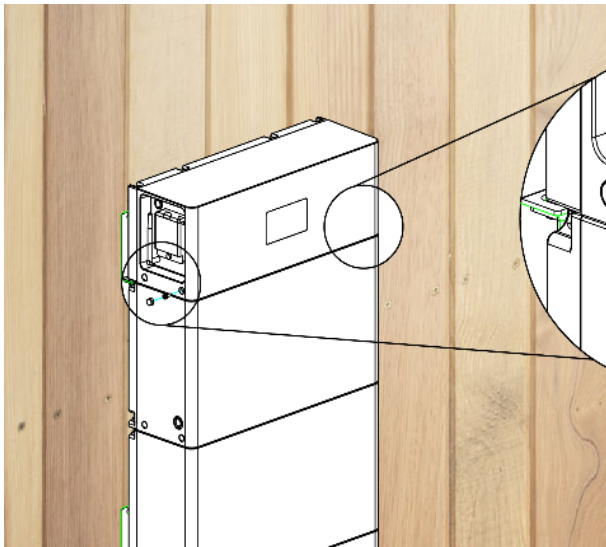


**Warning! Do not drop the non-connector end first to avoid damage to the connector!**

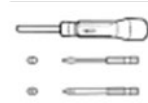
h. Control module installation

1. Fixed control module

When stacking the control module, align one end of the connectors and then drop them synchronously, then lock the screws on both sides of the control module, and install the screw cover.



Fixing screws M5\*12  
4pcs



Torque screwdriver



Screw cover 4pcs

## 2. Check model

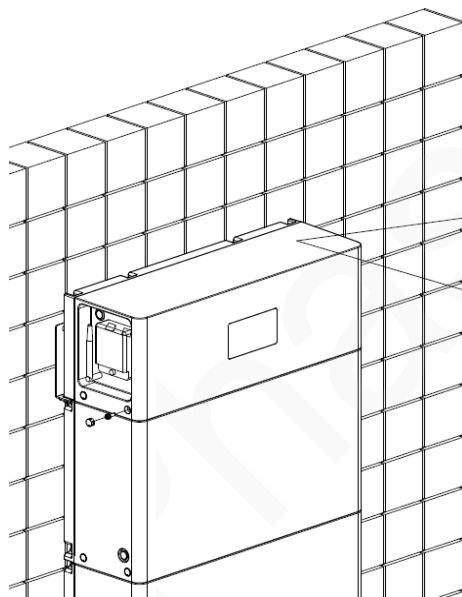
Tick the nameplate model according to the number of installed battery:

5kWh: PhG-ESS- 5L-S

10kWh: PhG-ESS-10L-S

15kWh: PhG-ESS-15L-S

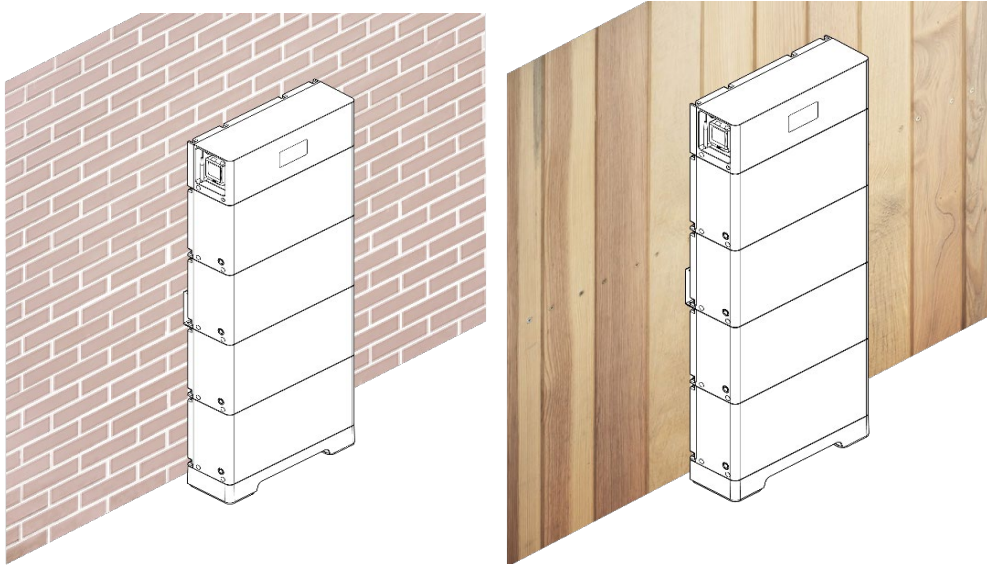
20kWh: PhG-ESS-20L-S



Model	PhG-ESS-5	PhG-ESS-10L	PhG-ESS-15L	PhG-ESS-20L
Battery Type	LiFePO4	LiFePO4	LiFePO4	LiFePO4
Rated Capacity	5kWh	10kWh	15kWh	20kWh
Max. Charge Current	150A	150A	200A	200A
Max. Discharge Current	150A	150A	200A	200A
Nominal Voltage	51.2Vdc			
Protection Class	IP65			
Operating Temperature	-20°C~50°C (Charge) / -20°C~60°C (Discharge)			
Maximum short-circuit current and duration time	3000A/1ms			
Manufacturer	PhaseGreen Technology Inc.			
Website	www.phasegreen.com			
MADE IN	CHINA			

i. Installation completed





## 4 Electrical connections



**NOTE:** Before connecting cables, make sure all systems are powered off.

### 4.1 Grounding instructions

The recommended equipment grounding cable specifications are as follows.

Specification	8AWG, yellow-green cable
Stripping size	8mm
Terminal	Ring terminal M6

Connect one end of the ring terminal of the ground wire to the ground point on the left side of the control module and the other end to the common ground point.

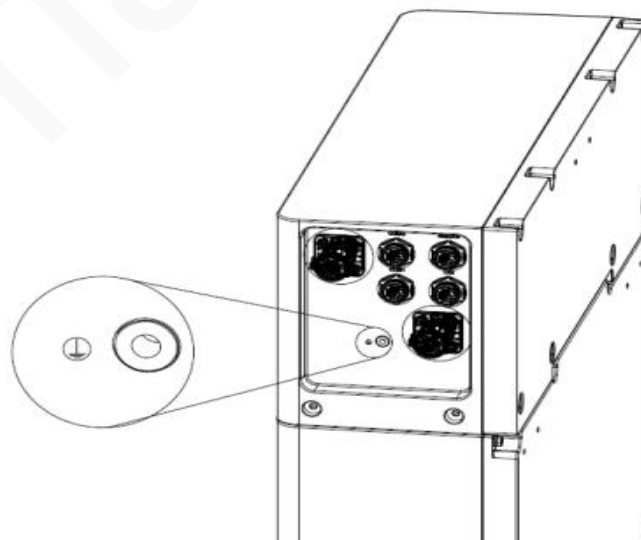
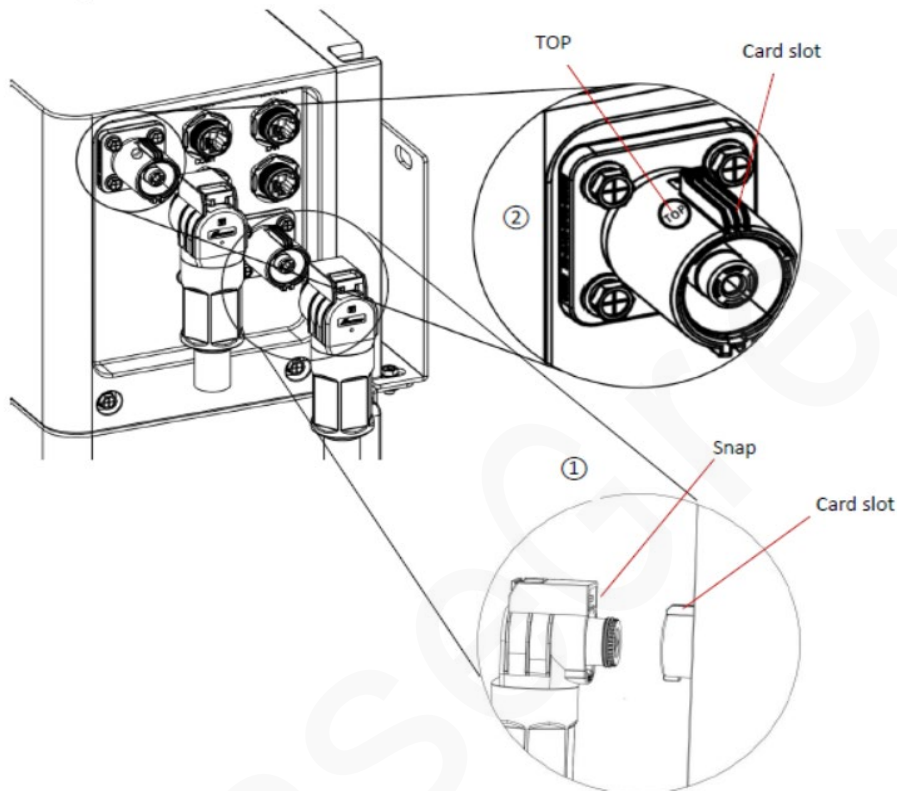


Figure 4-1-1 Schematic diagram of equipment grounding

## 4.2 Power connector installation

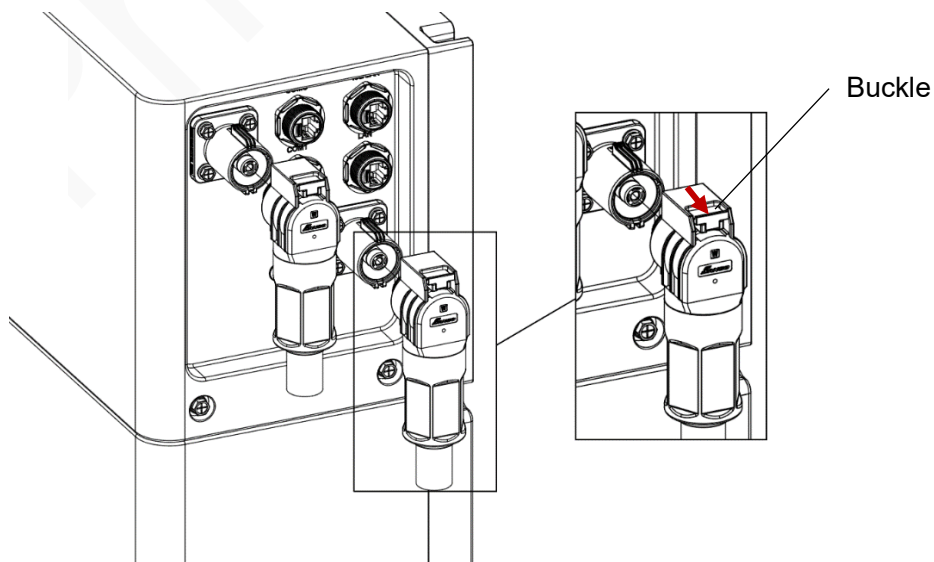
**NOTE:** Before connecting the power cable (DC+ & DC-) to the battery, ensure that the other end of the power cable is connected to Inverter or Combiner box.

a. When the wire harness connector is inserted into the card slot of the control box, the slot mark TOP of the card slot is at the top, and it is aligned with the snap of the wire harness connector (the long end card slot of the control box should face upwards when it is inserted), and then there is a clicking sound when plugging in, as shown in the figure:

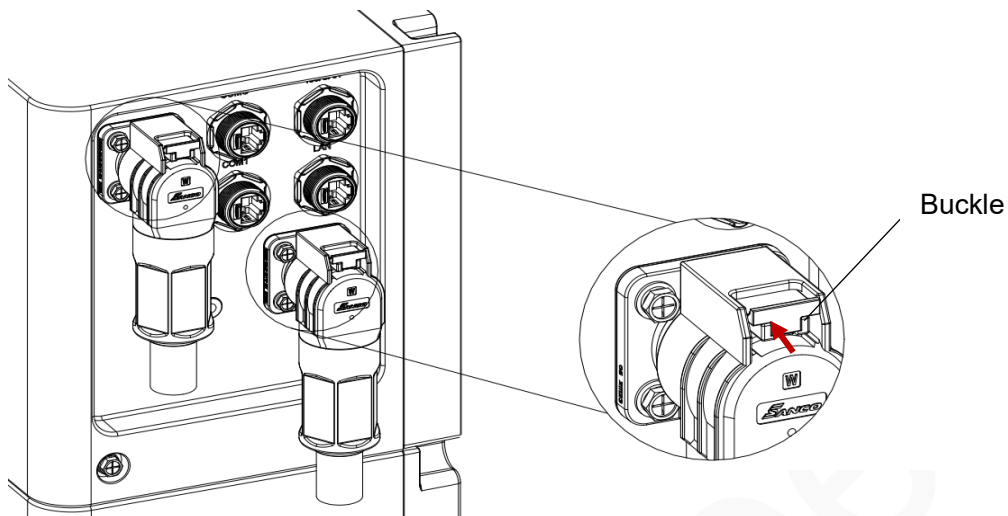


**Note:**

When inserting the terminals, check that the red buckle is open, as shown in the figure below.



b. After the installation is completed, push the red buckle into the lock, and the installation is complete, as shown in the figure.



### 4.3 Cable connection

#### 4.3.1 Single cabinet cable connection

The wiring of the device is shown in the figure below. For the wiring on the inverter side, please refer to the inverter user manual.

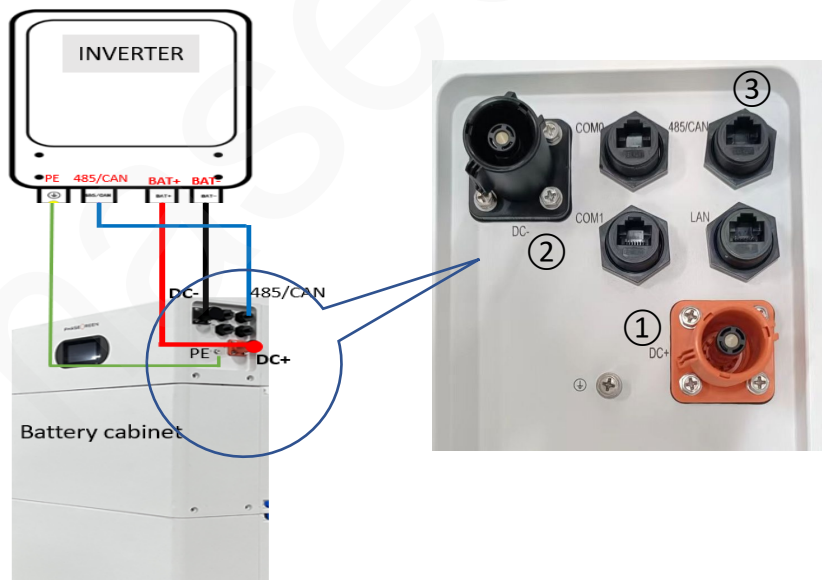
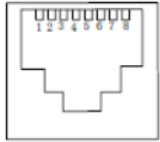


Figure 4-3-1 Wiring diagram of single machine system

No.	Harness name	Cable mark
①	Positive wire harness	DC+ PCS/BAT+
②	Negative wire harness	DC- PCS/BAT-
③	PCS- RS485/CAN communication cable	BAT PCS

RS485/CAN port pin definition of the control module:

Color	Port	Pin	Function
Orange-white	 RJ45	1	RS485A
Orange		2	RS485B
Green- white		3	
Blue		4	CANH
Blue- white		5	CANL
Green		6	
Brown-white		7	
Brown		8	

### 4.3.2 Cable connection of parallel cabinets

1. When the devices are connected to the inverter in parallel, the output positive and negative cables of each device are connected to the combiner box, and then the cables are connected from the combiner box to the inverter.
2. Up to 3 parallel connections are supported.
3. A Combiner box is required when two or more battery cabinet are used in parallel.

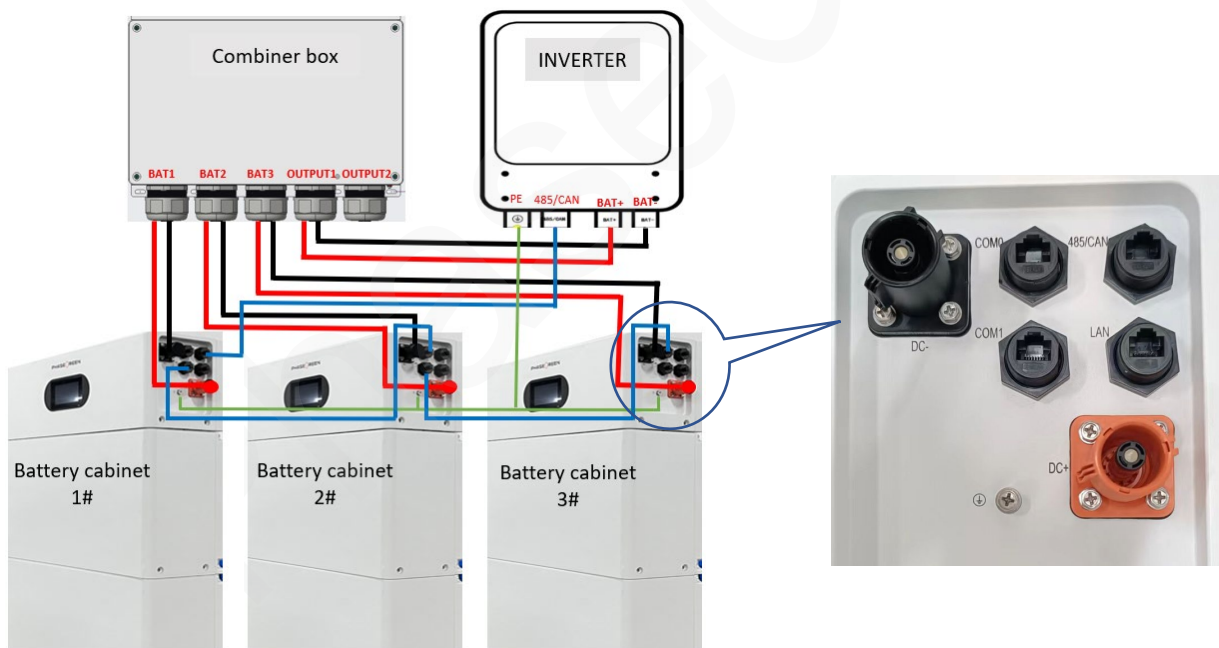


Figure 4-3-2a Wiring diagram of parallel system

4. The communication wiring between the battery cabinet is shown in the figure below.

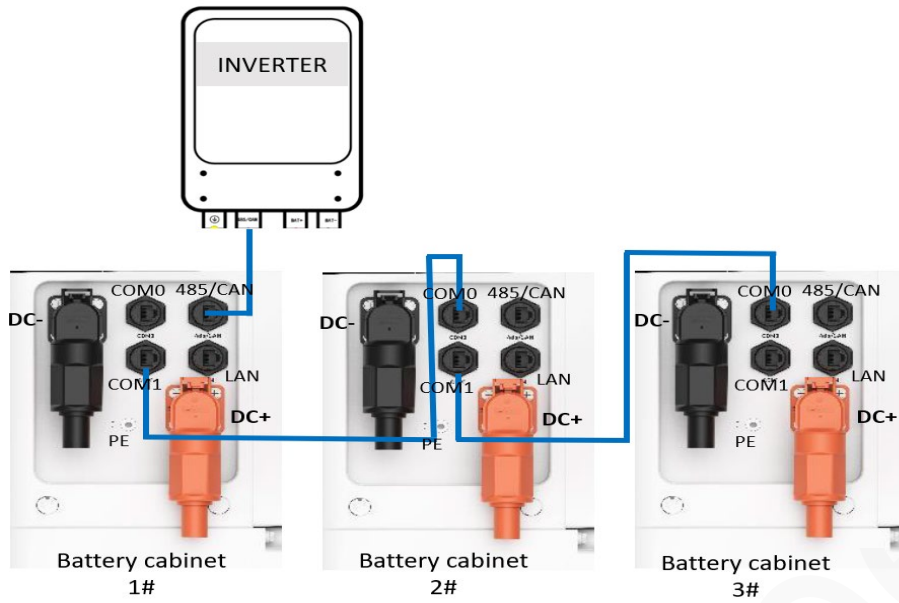
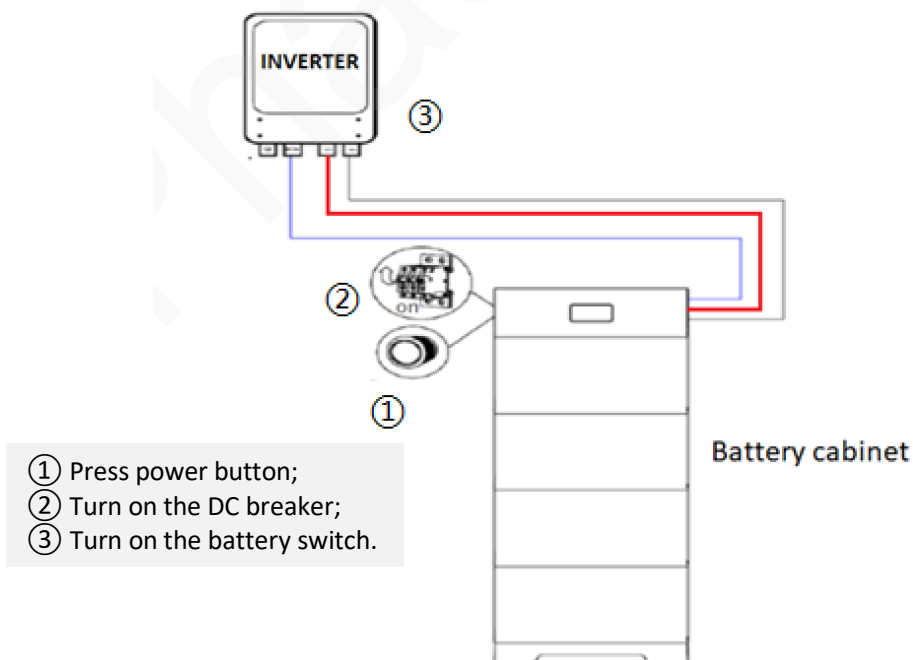


Figure 4-3-2b Communication wiring diagram of parallel system

## 5 System commission

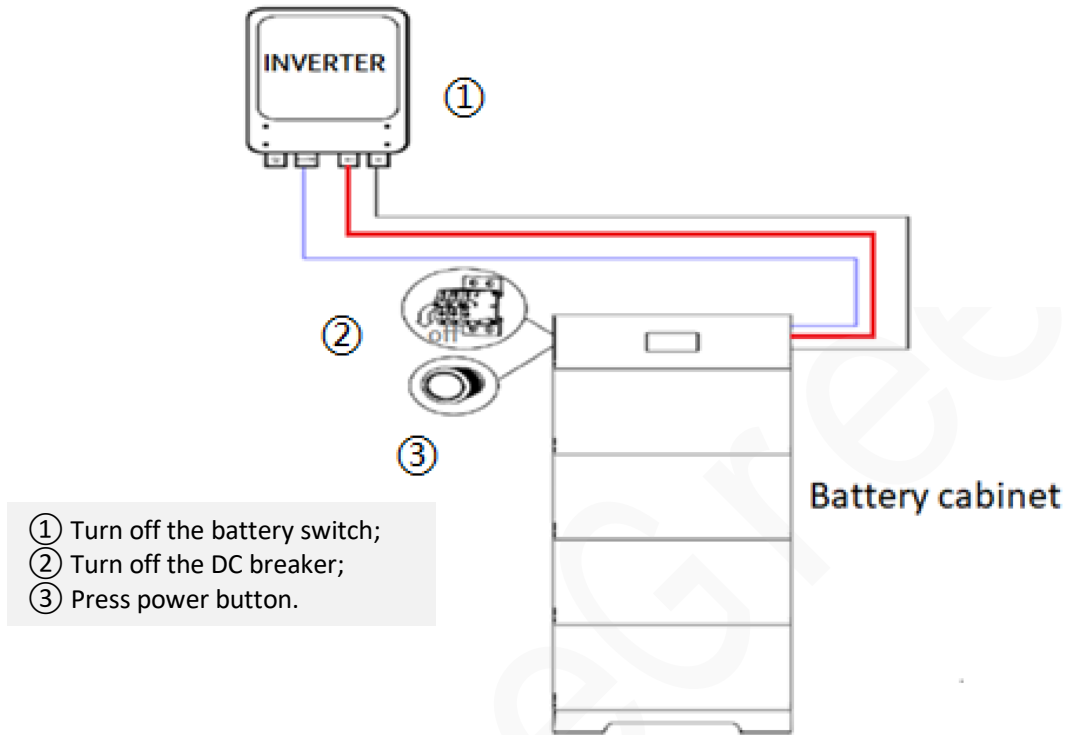
### 5.1 System power up steps

1. Press and hold the POWER button for more than 3s, the system starts and outputs voltage, and the display interface and the POWER button light is on blue color.
2. Turn on the control module DC breaker.
3. Then turn on the battery Switch on the inverter (if the inverter has a separate battery switch).



### 5.2 System power off steps

1. Turn off the battery Switch on the inverter (if the inverter has a separate battery switch).
2. Turn off the control module DC breaker, the system turns off the output.
3. Press and hold the POWER button for more than 3s, the display interface and the POWER button light go out.



### 5.3 Display description

After the display screen is displayed for 10 minutes, the screen will turn off. Short press the POWER button for 1s and the screen will light up again.

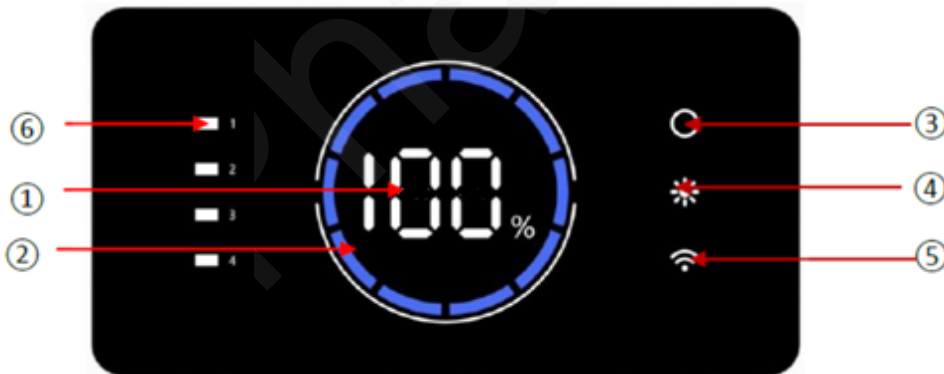


Table 5-3-1 Display description

Item	Description	Function
①	SOC	Digital display of real-time SOC value of energy storage system

②		The blue grid displays the real-time SOC value of the energy storage system. The blue grid flashes counterclockwise during charging, and remains unchanged when discharging
③	System status	Steady light means normal operation, flashing means system failure
④	Heating state	Steady on means the heating function inside the system is activated, and off means the heating function is not activated
⑤	Network status	Steady on means the WiFi network connection is successful, flashing means the WiFi network is not connected
⑥	Battery status module	Steady on means the battery is normal, flashing means the battery is faulty

## 5.4 System configuration

### NOTICE:

Please ignore content 5.4, if you are using PhaseGreen inverters with PhaseGreen batteries.

#### a. Download and install PowerLite APP



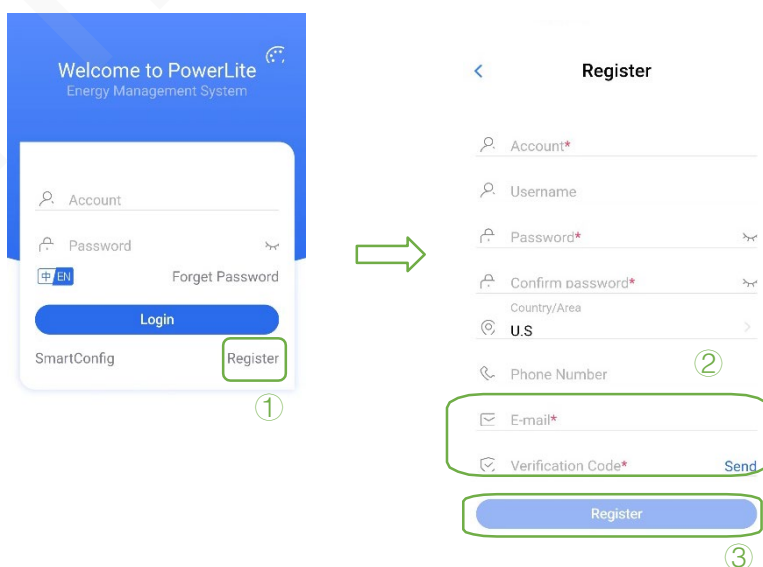
The battery parameter setting and remote monitoring can be realized through the APP software (PowerLite), please go to the App Store or Google Play to search for "PowerLite" to download and install.

#### b. Network configuration

1. Turn on your phone's Location, Wi-Fi and Bluetooth signal .

2. Click Register to go to register an account to complete the registration.

① Click "Register", ② Enter the registration interface and fill in the information, after receiving the verification by email, enter the verification code, ③ Click "Register", complete the registration.



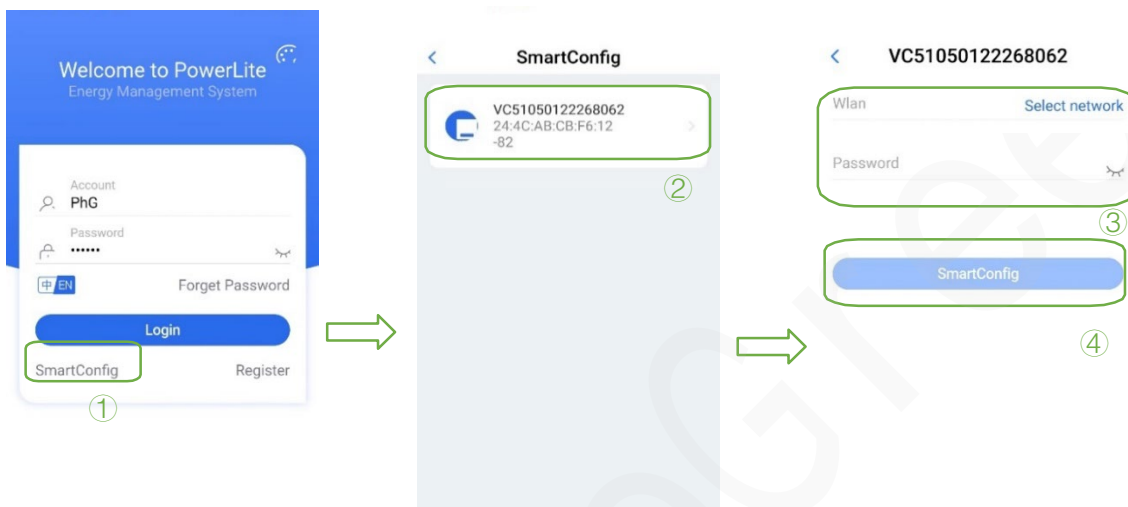


Note: If you have already registered a login account, please ignore this step.

### 3. Configure the network

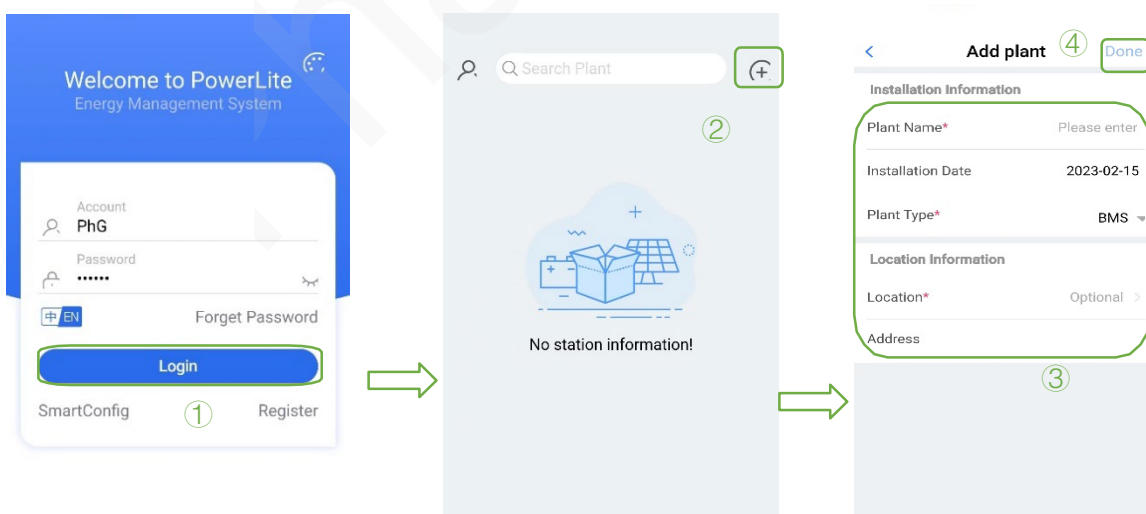
(You can check the Bluetooth SN code of the battery device at the antenna position of the control module)

① Click "SmartConfig", ② Select the Bluetooth device corresponding to the battery, ③ Click "select network", select the Wi-Fi network account and enter Wi-Fi password, ④ Click "SmartConfig" to complete the networking, the APP displays the successful network configuration information and the WiFi icon on the display is always on, that is, the network configuration is completed.



### c. Add site

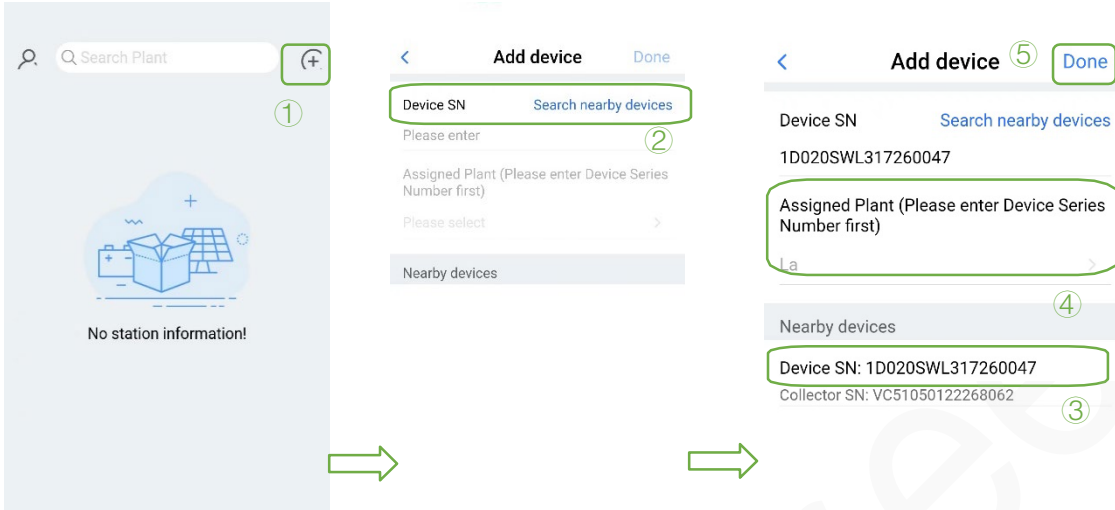
Enter the Account and password, ① Click "Login" to login, ② After login, click on the top right corner of the main interface to add a site, ③ After recommending a power station, ④ Click "Done", complete the site addition.



### d. Add device (Please check the battery equipment SN on the control box)

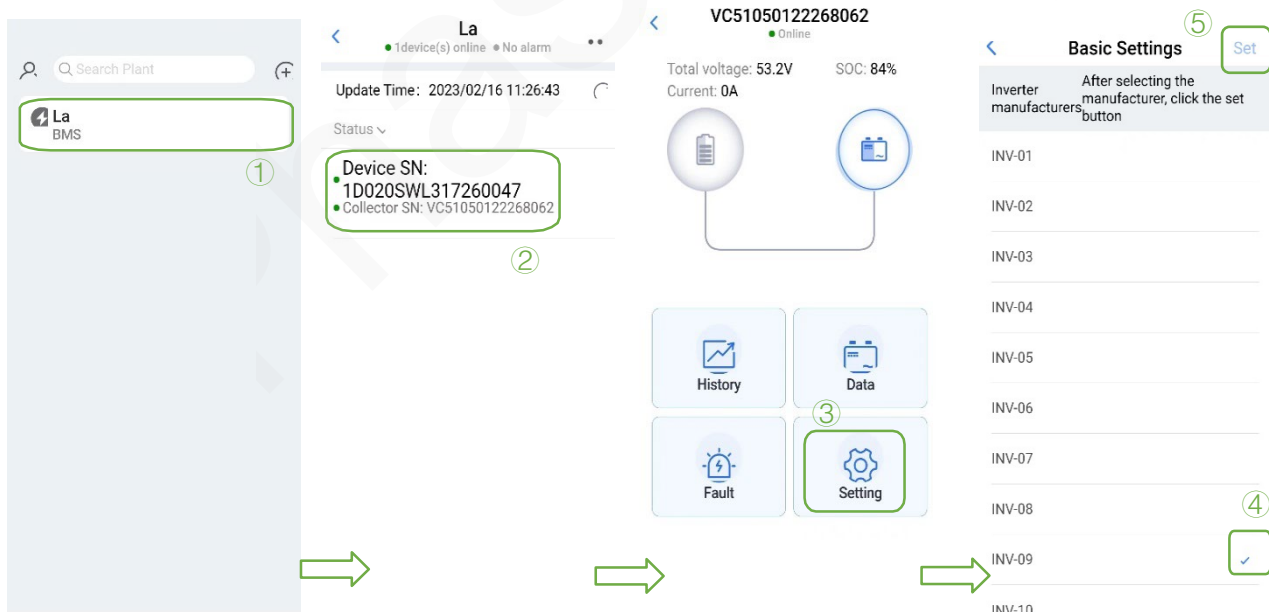


① Turn to the up step, click on the top right corner of the main interface to add a device, ② Click on the “search nearby device”, ③ Select and click the “device SN”, ④ Click "Assigned Plant" to bind the battery equipment to the established power station, ⑤ Click“Done”, complete the device addition.



e. Select inverter manufacturer

After the site/device is added successfully, ① Click to enter the corresponding site, ② Click the Bluetooth SN code of the battery device to enter the battery interface, and you can view the device data, ③Click “Setting” to enter the inverter manufacturer interface for selecting the battery system configuration, ④Select and click the matching inverter manufacturer, ⑤Click “Set”, the system configuration is completed.



**Inverter manufacturer list:**

Number	INV-01	INV-02	INV-03	INV-04	INV-05	INV-06	INV-07	INV-08	INV-09	INV-10
Inverter manufacturer	Sunwoda	Solax	Goodwe	Deye	SMA	Victron	Solis	Selectronic	PhaseGreen	LUXPOWER

## 6 Maintenance manual/general troubleshooting

### 6.1 Routine maintenance

- Maintenance charge every 6 months

From the date of manufacturer shipment, the battery shall be maintained every 6 months. Action must be taken in case SOC reaches 0% according to,

Ambient temperature	Must be recharged within
(45, 50] °C	7 days
(35, 45] °C	15 days
≤35°C	30 days

- Disconnect the battery if not being used

BMS consumes power even when the battery is not being used. Disconnect the battery output to prevent the battery from becoming empty. For store-away, make sure the SOC is between 45% and 55% before disconnect.

- Check the battery system regularly. Contact your support if any anomaly detected

### 6.2 Fault treatment

Fault	Cause	Solution
POWER button no response	Damaged POWER button, damaged cable, or poor contact	Please contact the supplier to repair or replace the control module
Short discharge time	battery is low	Keep the product charged continuously and keep the energy storage battery system fully charged
	low ambient temperature	Guarantee the product to work within the recommended suitable temperature range
	Product overload	Check load status and remove non-essential loads
	Batteries age and capacity decreases	To replace the battery, please contact the supplier for the battery and its components

Unable to charge and discharge	Internal failure	Please contact the supplier
	Battery report charging or discharging protection failure	please contact the supplier
	After the battery is discharged to the SOC protection value, it needs to be charged for a period of time before it is allowed to discharge.	The battery is charged to the SOC value set by the restart
	battery over temperature	Stand at room temperature for more than 3 hours
After the system is powered on, the display cannot be lit or the displayed content is abnormal	Display failure	Please contact the supplier to repair or replace the control module
The display cannot wake up and light up during system operation	1. If the POWER button light is off, the POWER button is faulty, or the button wiring is loose	Please contact the supplier to repair or replace the control module
	2. If the display still does not light up after restarting, the display is faulty	
Abnormal communication battery	Communication disconnection	Check whether the battery stack is installed reliably, and confirm the abnormal battery through the battery status indicator on the display
The system status light on the display is abnormal and blinks every 1S	other	Please view the fault information and contact the supplier
The heater works abnormally, and the heating status indicator on the display flashes every 1S	Heating circuit failure	Please view the fault information and contact the supplier
Abnormal Bluetooth connection	Bluetooth account connect error	Check whether the paired Bluetooth is consistent with the installed product

Abnormal WiFi connection	<ol style="list-style-type: none"> <li>1. The WiFi connection is misconfigured</li> <li>2. The WiFi module is abnormal, and the line connection is abnormal</li> </ol>	<ol style="list-style-type: none"> <li>1. Check if the battery WiFi connection configuration is correct</li> <li>2. Check whether the antenna is installed or connected reliably</li> </ol>
The inverter is powered on for the first time through the battery, and the battery reports short-circuit protection	The parallel capacitor value of the input terminal on the battery side of the inverter is large	Battery protection can be Automatically restored
Inverter won't start	The battery voltage is too low or the SOC is lower than the shutdown protection value	Charge the battery after starting the inverter from the grid

## 7 Warehouse storage guidelines

The battery pack is stored in a clean, dry and ventilated room with an ambient temperature of  $25^{\circ}\text{C}\pm 5^{\circ}\text{C}$  and a relative humidity of not more than 75%. The battery pack has a state of charge of 45% to 55%. Avoid contact with corrosive substances and keep away from fire and heat sources.

## 8 Dispose of used batteries

Comply with applicable local regulations for the disposal of electronic waste and used batteries.

- Do not mix with your household waste.
- Do not expose the battery to high temperatures or direct sunlight.
- Do not expose batteries to high humidity or corrosive environments.

Contact supplier or original manufacturer for disposal options.

## 9 Detailed specification

### System Specification

Item	Parameter			
	PhG-ESS-5L	PhG-ESS-10L	PhG-ESS-15L	PhG-ESS-20L
System model				
Nominal energy (kWh)	5	10	15	20
Usable energy 90%DOD (kWh)	4.5	9	13.5	18

Rated voltage (V)	51.2	51.2	51.2	51.2
Rated charge/discharge current (A)	50/50	100/100	150/150	200/200
Max. charge/discharge current (A)	100/100	180/180	200/200	200/200
Max. continuous discharge rate(kW)	5	9	10	10
Voltage range (V)	44.8~55.2	44.8~55.2	44.8~55.2	44.8~55.2
Roundtrip efficiency	95%	95%	95%	95%
Dimensions W*H*D	573*597*189mm (22.6*23.5*7.4 in)	573*912*189 mm (22.6*35.9*7.4 in)	573*1227*189 mm (22.6*48.3*7.4 in)	573*1542*189 mm (22.6*60.7*7.4 in)
Weight	65kg (143 lb)	115kg(254 lb)	165kg(364 lb)	215kg (474 lb)
Communication interface	CAN / RS485/ WiFi			
Cycle life	6000 times (25C, 0.5C/0.5C, 90%DOD, 70% remaining)			
DC disconnect	Circuit breaker, 250A, 48V rating			
Connection method	Quick plug and unplug terminals			
User interface	Display battery running status, SOC, alarm information, WIFI status,, heater status, etc.			
Protection features	Charging overvoltage protection, discharge under-voltage Protection features protection, over current protection, over temperature protection ,short circuit protection, etc.			
Scalability	Max. 3 x 20kWh systems in parallel, expandable capacity of 60kWh			
Protection class	IP55			
Charging temperature	-10°C to 50°C (14°F to 122°F)			
Discharging temperature	-20°C to 50°C (-4°F to 122°F)			
Storage temperature	-30°C to 60°C (-22°F to 140°F)			
Humidity	10% to 95%,non condensation			
Enclosure rating	IP55			
Altitude	2000 m (6562 ft)			
Cooling	Natural convection			
Certification	IEC/EN62619, EN/IEC61000, EN62311, EN300328, EN301489, UL1973, FCC part15B, UL9540, UL1642, UN38.3, MSDS			

## 10 Contact information

Regional division technical service contact information

PhaseGreen Technology Inc.

Address: 3041 El Camino Real, Palo Alto, CA 94306, USA

Email: [info@phasegreen.com](mailto:info@phasegreen.com)

Website: [www.phasegreen.com](http://www.phasegreen.com)

Customer services telephone:

USA (+1) 510 502 6796

EUR (+31) 202 446 533

Global (+1) 541 653 2228

PhaseGreen